

HOW TO READ THE STANDARD OF THREADING

How this section page is organised

- ① Classified according to external or internal applications.
- ② Sub-classified according to product series.
(Refer to the index on the next page.)

FIGURE SHOWING THE TOOLING APPLICATION uses illustrations and arrows to depict the available machining applications, such as external and internal threading.

TYPE OF TOOL HOLDER indicates the initial letters for the order number and cutting applications.

TITLE OF PRODUCT INDICATES THE INITIAL LETTERS FOR THE ORDER NUMBER AND CUTTING APPLICATIONS.

STANDARDS FOR APPLICABLE INSERTS indicates stock status, dimensions, etc. for applicable inserts.

MMTI TYPE BORING BARS

Internal Threading

Order Number	R	Insert Number	Lead Angle (°)	DCOM	LF	LF2	WF	H	DMIN	DMAX	Grade	Applicable Holder	Applicable Angle (°)
MMTR1316AK11-SP16	R	MMT11R	1.5°	16	125	25	8.7	15	13	—	T320	—	—
MMTR1316AK11-SP25	R	MMT11R	2.5°	16	125	25	8.7	15	13	—	T320	—	—
MMTR1316AK11-SP35	R	MMT11R	3.5°	16	125	25	8.7	15	13	—	T320	—	—
MMTR1516AM11-SP15	R	MMT15R	1.5°	16	150	32	9.7	15	15	—	T320	—	—
MMTR1516AM11-SP25	R	MMT15R	2.5°	16	150	32	9.7	15	15	—	T320	—	—
MMTR1516AM11-SP35	R	MMT15R	3.5°	16	150	32	9.7	15	15	—	T320	—	—

Notes: Select and use a shim as shown below (hold serration) depending on the lead angle. A screw-on tool holder uses no shim. (The holder body has a lead angle.) Use a tool holder with the appropriate lead angle. Min. cutting diameter (Dmin) shows the internal hole diameter, not the thread diameter.

MMT M-CLASS INSERTS WITH 3-D CHIP BREAKERS

INSERTS

Type	Order Number	Chip Width (mm)	Pitch (mm)	IC (mm)	S (mm)	PCV (°)	PDX (°)	RE (mm)	Total Cutting Depth (mm)	Geometry
Partial Profile (R)	MMT11RA60-S	0.3-1.0	40-16	0.35	3.04	0.8	0.9	0.03	—	Partial form
	MMT16RA60-S	0.0-1.0	40-16	0.525	3.44	0.8	0.9	0.03	—	Partial form
	MMT16RG60-S	1.75-3.0	14-5	0.525	3.44	1.2	1.7	0.11	—	Partial form
ISO Metric	MMT11R1000-S	1.0	—	0.35	3.04	0.6	0.7	0.06	0.58	Full form
	MMT11R1500-S	1.5	—	0.35	3.04	0.8	1.0	0.10	0.87	Full form
	MMT11R2000-S	2.0	—	0.35	3.04	0.6	0.7	0.06	0.58	Full form

IDENTIFICATION

MMT 16 I R 100 ISO - S

Designation: MMT 16 I R 100 ISO - S

Hand of Tool: R (Right), L (Left)

Application: 100 (100mm), 150 (150mm), 200 (200mm), 300 (300mm), 500 (500mm)

Pitch: A (0.5-1.5mm), G (1.75-3.0mm), H (4.0-16mm)

Threading Type: S (Standard), W (Weldon), B (Bore)

RECOMMENDED CUTTING CONDITIONS

Work Material	Hardness	Grade	Cutting Speed (m/min)	Work Material	Hardness	Grade	Cutting Speed (m/min)
Mild Steel	F180H	VP18MF	150 (15-25)	Heat-Resistant Alloy	—	VP18MF	45 (15-25)
Carbon Steel	F180H	VP18MF	100 (10-20)	Titanium Alloy	—	VP18MF	85 (10-20)
Alloy Steel	F180H	VP18MF	80 (10-20)	Heat-Treated Alloy	45-60HRC	VP18MF	50 (10-20)
Stainless Steel	F200H	VP18MT	80 (10-20)				
Gray Cast Iron	F300H	VP18ST	80 (10-20)				

Inventory maintained in Japan. (S inserts in one case)

HOW TO SELECT A HOLDER: MMT SERIES CHECK NUMBER → G026

LEGEND FOR STOCK STATUS MARK is shown on the left hand page of each double-page spread.

PRODUCT STANDARDS indicates order numbers, stock status (per right/left hand), applicable inserts, holder dimensions, and spare parts.

PAGE REFERENCE - SPARE PARTS indicates reference pages, including the above, on the right hand page of each double-page spread.

RECOMMENDED CUTTING CONDITIONS for each work material classification, indicates recommended cutting conditions according to the ISO categories for cutting grades, P, M, K, S, and H.

To Order : For holder, please specify ①order number and hand of tool (right/left). For insert, please specify ①insert number and ②grade.

TURNING TOOLS

THREADING

CLASSIFICATION (EXTERNAL THREADING) G002
 CLASSIFICATION (INTERNAL THREADING)..... G003
 CROSS REFERENCE OF THREAD PITCHES
 EXTERNAL G004
 INTERNAL G006
 STANDARD THREAD AND CORRESPONDING INSERT / HOLDER..... G008

STANDARD OF THREADING TOOLS

MMT SERIES

FEATURES G010
 CUTTING CONDITIONS..... G012
 STANDARD OF DEPTH OF CUT..... G014

EXTERNAL THREADING

MMTE HOLDER G019
 MT HOLDER G024
 SMG HOLDER G026

INTERNAL THREADING

MMTI TYPE BORING BARS G028
 MICRO-MINI TWIN BORING BARS G033
 F TYPE BORING BARS G036
 D TYPE BORING HEAD G038

*Arranged by Alphabetical order

G033 CT
 G038 DPT2
 G036 FSL51
 G036 FSL52
 G037 MLG (INTERNAL INSERTS)
 G037 MLT (INTERNAL INSERTS)
 G020 MMT (EXTERNAL INSERTS)
 G029 MMT (INTERNAL INSERTS)
 G019 MMTE
 G028 MMTI
 G024 MT1
 G024 MTH
 G025 MTT (EXTERNAL INSERTS)
 G039 MTT (INTERNAL INSERTS)
 G035 RBH
 G034 SBH
 G026 SMGH
 G027 SMGT (EXTERNAL INSERTS)
 G027 SMTT (EXTERNAL INSERTS)



CLASSIFICATION (EXTERNAL THREADING)

Name of Tool Holder	Insert Shape	Features	Shank Size (H x W x L) (mm)	
MMTE Holder  		<ul style="list-style-type: none"> ● Various insert types. ● M-class 3-D breaker inserts and G-class ground inserts available. ● Available with a wiper cutting edge to provide a precise thread geometry. ● Able to change lead angle by replacing shim. 	12 x 12 x 100 16 x 16 x 100 20 x 20 x 125 25 x 25 x 150 32 x 32 x 170	
MT Holder  		<ul style="list-style-type: none"> ● Clamp-on type. ● Precision class insert. ● Positive insert suffers from negligible chattering and thus produces good finished surface. 	16 x 16 x 100 20 x 20 x 125 25 x 25 x 150 32 x 32 x 170	
SMG Holder  		<ul style="list-style-type: none"> ● Screw-on type. ● Precision class insert. ● Positive insert suffers from negligible chattering and thus produces good finished surface. ● Holder is capable of performing both threading and grooving. 	10 x 10 x 70 12 x 12 x 80 16 x 16 x 100 20 x 20 x 125 25 x 25 x 150	
SMALL TOOLS	TTAH  		<ul style="list-style-type: none"> ● Tools to be equipped on Gang type tool posts. ● Small Shank: 8mm—16mm ● High rigidity due to designing of vertical insert. ● The screw designed for common use on front and back enables back clamping. ● Most suitable for threading diameters of 2 mm or smaller. ● Screw-on type. 	8 x 10 x 120 10 x 10 x 120 12 x 12 x 120 16 x 16 x 120
	CSVH  		<ul style="list-style-type: none"> ● Tools to be equipped on Cam type tool posts. ● Small Shank: 7mm—12mm ● Single holder for front turning, back turning, grooving, threading and cutting off operations. ● The most suitable for machining of small parts with work diameter ϕ5mm or less. ● Screw-on type. 	7 x 7 x 140 8 x 8 x 140 9.5 x 9.5 x 140 10 x 10 x 140 12 x 12 x 140

G

THREADING

CLASSIFICATION (INTERNAL THREADING)

Name of Tool Holder	Insert Shape	Features	Shank Size (Dia. x L x Min. Cutting Dia.) (mm)
MMTI   G028		<ul style="list-style-type: none"> ● Minimum cutting diameter 13mm. ● Various insert types. ● M-class 3-D breaker inserts and G-class ground inserts available. ● Available with a wiper cutting edge to provide a precise thread geometry. ● Able to change lead angle by replacing shim. 	16 x 125 x 13 16 x 150 x 15 20 x 170 x 24 25 x 200 x 29 32 x 250 x 37 40 x 300 x 46
FSL5   G036		<ul style="list-style-type: none"> ● Minimum cutting diameter 10mm. ● Screw-on type. ● Precision class insert. ● Applicable for threading, grooving and boring. ● Available with a carbide shank to prevent vibration when machining deep holes. 	8 x 125 x 10 10 x 150 x 12 12 x 180 x 14 14 x 180 x 16 16 x 200 x 20
DPT2   G038		<ul style="list-style-type: none"> ● Minimum cutting diameter 40mm. ● Pin lock type. ● Precision class insert. ● Exchangeable head type. 	32 x 300 x 40 40 x 360 x 50
MICRO-MINI TWIN Boring Bars   G033	—	<ul style="list-style-type: none"> ● Minimum cutting diameter 3mm. ● Solid carbide type. ● Economical two cutting edge type. 	3 x 50 x 3 4 x 60 x 4.5 5 x 70 x 6 6 x 75 x 7
MICRO-MINI Boring Bars   E022	—	<ul style="list-style-type: none"> ● Minimum cutting diameter 3.2mm. ● Solid carbide type. ● Insert can be ground to suit the application. 	3 x 80 x 3.2 4 x 80 x 4.2 5 x 100 x 5.2



THREADING

CROSS REFERENCE OF THREAD PITCHS (EXTERNAL)

Application		General machining				Pipe fittings and couplings for gas and water	
Type	Partial Profile 60°	Partial Profile 55°	ISO Metric	American UN	Parallel Pipe Thread Whitworth for BSW, BSP	American NPT	
Type							
Symbol	M UNC UNF	W	M	UNC UNF	G(PF) Rp(PS) W	NPT	
Pitch	mm (thread/inch)	thread/inch	mm	thread/inch	thread/inch	thread/inch	
Holder							
 MMT Holder ↻ G019	Full form	—	—	0.5—5.0	32—5	28—5	27, 18, 14 11.5, 8
	Partial form	0.5—5.0 (48—5)	48—5	0.5—5.0	48—5	—	—
 MT Holder ↻ G024	Partial form	0.25—4.5 (64—6)	20—9	0.25—4.5	64—6	—	—
 SMG Holder ↻ G026	Partial form	0.25—2.0 (48—13)	—	0.25—2.0	48—13	—	—

G
THREADING

	Steam, gas and water line pipes		Pipe couplings for food and fire fighting industries	Motion transmissions		Aircraft and aerospace	Oil and gas	
	Taper Pipe Thread BSPT	American NPTF	Round DIN 405	ISO Trapezoidal 30°	American ACME	UNJ	API Buttress Casing	API Round Casing&Tubing
	R(PT) Rc(PT) Rp	NPTF	Rd	Tr (TM)	ACME (Tw)	UNJ	BCSG	CSG LCSG
	thread/inch	thread/inch	thread/inch	mm	thread/inch	thread/inch	thread/inch	thread/inch
	28, 19 14, 11	27, 18, 14 11.5, 8	10, 8 6, 4	1.5, 2 3, 4, 5	12, 10 8, 6, 5	32—8	5	10, 8
	—	—	—	—	—	—	—	—
	—	—	—	—	—	—	—	—
	—	—	—	—	—	—	—	—



THREADING

CROSS REFERENCE OF THREAD PITCHS (INTERNAL)

Application		General machining				Pipe fittings and couplings for gas and water	
Type		Partial Profile 60°	Partial Profile 55°	ISO Metric	American UN	Parallel Pipe Thread Whitworth for BSW, BSP	American NPT
Symbol		M UNC UNF	W	M	UNC UNF	G(PF) Rp(PS) W	NPT
Holder	Pitch	mm (thread/inch)	thread/inch	mm	thread/inch	thread/inch	thread/inch
MMT Boring Bars ↻ G028	Full form	—	—	0.5—5.0	32—5	28—5	27, 18, 14 11.5, 8
	Partial form	0.5—5.0 (48—5)	48—5	0.5—5.0	48—5	—	—
FSL5 Boring Bars ↻ G036	Partial form	1.5—3.5 (16—8)	—	1.5—3.5	16—8	—	—
DPT2 Boring Head ↻ G038	Partial form	1.0—3.5	—	1.0—3.5	—	—	—
MICRO-MINI TWIN ↻ G033	Partial form	0.5—1.75 (36—16)	—	0.5—1.75	36—16	—	—

G

THREADING

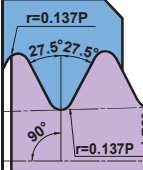
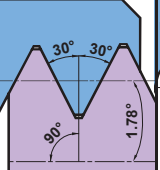
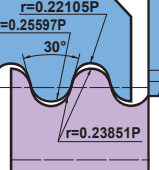
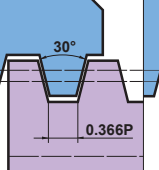
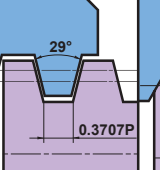
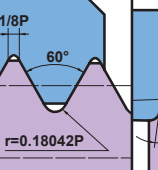
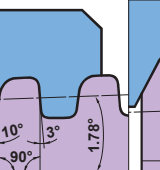
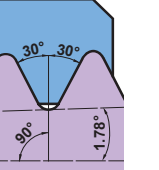
	Steam, gas and water line pipes		Pipe couplings for food and fire fighting industries	Motion transmissions		Aircraft and aerospace	Oil and gas	
	Taper Pipe Thread BSPT	American NPTF	Round DIN 405	ISO Trapezoidal 30°	American ACME	UNJ	API Buttress Casing	API Round Casing&Tubing
								
	R(PT) Rc(PT) Rp	NPTF	Rd	Tr (TM)	ACME (Tw)	UNJ	BCSG	CSG LCSG
	thread/inch	thread/inch	thread/inch	mm	thread/inch	thread/inch	thread/inch	thread/inch
	19, 14, 11	14, 11.5, 8	10, 8 6, 4	1.5, 2 3, 4, 5	12, 10 8, 6, 5	—	5	10, 8
	—	—	—	—	—	*	—	—
	—	—	—	—	—	—	—	—
	—	—	—	—	—	—	—	—
	—	—	—	—	—	—	—	—

* When machining an internal UNJ thread, cut an internal hole with the appropriate diameter. Then machine with 60° American UN. In this case, a full form type insert cannot be used.



THREADING

STANDARD THREAD AND CORRESPONDING INSERT / HOLDER

G

THREADING

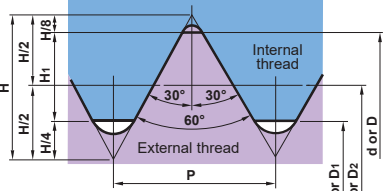
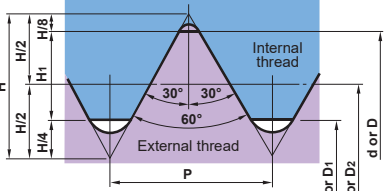
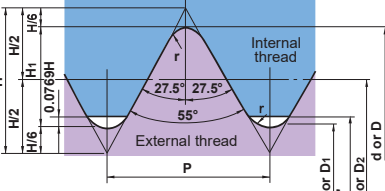
Thread Name	Standard Thread Type	Type	Ext./Int.	Insert Number	Wiper/General	Tool Holder	Page			
ISO Metric	 <p> $H=0.866025P$ $d_2=d-0.649519P$ $H_1=0.541266P$ $d_1=d-1.082532P$ $D=d$ $D_2=d_2$ $D_1=d_1$ </p>	M	Ext.	MMT $\odot\odot$ ER $\odot\odot\odot$ ISO	Wiper	MMTER $\odot\odot\odot\odot\odot$ -C	G019			
				MMT $\odot\odot$ ER $\odot\odot\odot$ ISO-S	Wiper					
				MMT $\odot\odot$ ER $\odot\odot\odot$ 60	General					
				MMT $\odot\odot$ ER $\odot\odot\odot$ 60-S	General					
				SMTTR/L160360 $\odot\odot$	General					
			MTTR/L4360 $\odot\odot$	General	SMGHR/L $\odot\odot\odot\odot$ 16	G026				
									MTHR/L $\odot\odot\odot\odot$ 4	G024
									MT1R/L $\odot\odot\odot\odot$ 4	
			Int.	MMT $\odot\odot$ IR $\odot\odot\odot$ ISO	Wiper	MMTIR $\odot\odot$ A $\odot\odot\odot$ -SP \odot	G028			
				MMT $\odot\odot$ IR $\odot\odot\odot$ ISO-S	Wiper					
MMT $\odot\odot$ IR $\odot\odot\odot$ 60	General									
MMT $\odot\odot$ IR $\odot\odot\odot$ 60-S	General									
MTTR/L4360 $\odot\odot$	General	DPT2 $\odot\odot\odot$ R	G038							
American UN	 <p> $H=0.866025 \times 25.4/n$ $d_2=(d-0.649519/n) \times 25.4$ $H_1=0.541266 \times 25.4/n$ $d_1=(d-1.082532/n) \times 25.4$ $d=(d) \times 25.4$ $D=d$ $D_2=d_2$ $D_1=d_1$ $P=25.4/\text{thread}$ </p>	UNC UNF	Ext.	MMT $\odot\odot$ ER $\odot\odot\odot$ UN	Wiper	MMTER $\odot\odot\odot\odot\odot$ -C	G019			
				MMT $\odot\odot$ ER $\odot\odot\odot$ UN-S	Wiper					
				MMT $\odot\odot$ ER $\odot\odot\odot$ 60	General					
				MMT $\odot\odot$ ER $\odot\odot\odot$ 60-S	General					
				SMTTR/L160360 $\odot\odot$	General					
			MTTR/L4360 $\odot\odot$	General	SMGHR/L $\odot\odot\odot\odot$ 16	G026				
									MTHR/L $\odot\odot\odot\odot$ 4	G024
									MT1R/L $\odot\odot\odot\odot$ 4	
			Int.	MMT $\odot\odot$ IR $\odot\odot\odot$ UN	Wiper	MMTIR $\odot\odot$ A $\odot\odot\odot$ -SP \odot	G028			
				MMT $\odot\odot$ IR $\odot\odot\odot$ UN-S	Wiper					
MMT $\odot\odot$ IR $\odot\odot\odot$ 60	General									
MMT $\odot\odot$ IR $\odot\odot\odot$ 60-S	General									
MTTR/L4360 $\odot\odot$	General	DPT2 $\odot\odot\odot$ R	G038							
Whitworth for BSW, BSP	 <p> $H=0.9605P$ $d_2=d-H_1$ $d_1=d-2H_1$ $r=0.1373P$ $H_1=0.6403P$ $D_1'=d_1+2 \times 0.0769H$ $D=d$ $D_2=d_2$ $D_1=d_1$ $P=25.4/\text{thread}$ </p>	W	Ext.	MMT $\odot\odot$ ER $\odot\odot\odot$ W	Wiper	MMTER $\odot\odot\odot\odot\odot$ -C	G019			
				MMT $\odot\odot$ ER $\odot\odot\odot$ W-S	Wiper					
				MMT $\odot\odot$ ER $\odot\odot\odot$ 55	General					
				MMT $\odot\odot$ ER $\odot\odot\odot$ 55-S	General					
			MTTR/L4355 $\odot\odot$	General	MTHR/L $\odot\odot\odot\odot$ 4	G024				
					MT1R/L $\odot\odot\odot\odot$ 4					
			Int.	MMT $\odot\odot$ IR $\odot\odot\odot$ W	Wiper	MMTIR $\odot\odot$ A $\odot\odot\odot$ -SP \odot	G028			
				MMT $\odot\odot$ IR $\odot\odot\odot$ W-S	Wiper					
MMT $\odot\odot$ IR $\odot\odot\odot$ 55	General									
MMT $\odot\odot$ IR $\odot\odot\odot$ 55-S	General									
MTTR/L4355 $\odot\odot$	General	DPT2 $\odot\odot\odot$ R	G038							

Wiper : Insert order number is determined by selected pitch.
 General : An insert is applicable to several pitch types.

Thread Name	Standard Thread Type	Type	Ext./Int.	Insert Number	Wiper/General	Tool Holder	Page
Parallel Pipe Thread	<p> $H=0.960491P$ $d_2=d-h$ $d_1=d-2h$ $r=0.137329P$ $h=0.640327$ $D=d$ $D_2=d_2$ $D_1=d_1$ $25.4/\text{thread}$ </p>	PF G Rp	Ext.	MMT $\odot\odot\odot$ ER $\odot\odot\odot$ W	Wiper	MMTER $\odot\odot\odot\odot\odot\odot$ -C	G019
				MMT $\odot\odot\odot$ ER $\odot\odot\odot$ W-S	Wiper		
			Int.	MMT $\odot\odot\odot$ IR $\odot\odot\odot$ W	Wiper	MMTIR $\odot\odot\odot$ A $\odot\odot\odot$ -SP \odot	G028
				MMT $\odot\odot\odot$ IR $\odot\odot\odot$ W-S	Wiper	MMTIR $\odot\odot\odot$ A \odot 16-C	
BSPT	<p> $H=0.960237P$ $h=0.640327$ $r=0.137278P$ $P=25.4/\text{thread}$ </p>	BSPT	Ext.	MMT $\odot\odot\odot$ ER $\odot\odot\odot$ BSPT	Wiper	MMTER $\odot\odot\odot\odot\odot\odot$ -C	G019
				MMT $\odot\odot\odot$ ER $\odot\odot\odot$ BSPT-S	Wiper		
			Int.	MMT $\odot\odot\odot$ IR $\odot\odot\odot$ BSPT	Wiper	MMTIR $\odot\odot\odot$ A $\odot\odot\odot$ -SP \odot	G028
				MMT $\odot\odot\odot$ IR $\odot\odot\odot$ BSPT-S	Wiper	MMTIR $\odot\odot\odot$ A \odot 16-C	
Round DIN 405	<p> $a_c=0.05 \times P$ $h_3=H_4=0.5 \times P$ $R_1=0.238507 \times P$ $R_2=0.255967 \times P$ $R_3=0.221047 \times P$ </p>	Rd	Ext.	MMT $\odot\odot\odot$ ER $\odot\odot\odot$ Rd	Wiper	MMTER $\odot\odot\odot\odot\odot\odot$ -C	G019
			Int.	MMT $\odot\odot\odot$ IR $\odot\odot\odot$ Rd	Wiper	MMTIR $\odot\odot\odot$ A $\odot\odot\odot$ -SP \odot	MMTIR $\odot\odot\odot$ A \odot 16-C
ISO Trapezoidal 30°		Tr	Ext.	MMT $\odot\odot\odot$ ER $\odot\odot\odot$ TR	Wiper	MMTER $\odot\odot\odot\odot\odot\odot$ -C	G019
			Int.	MMT $\odot\odot\odot$ IR $\odot\odot\odot$ TR	Wiper	MMTIR $\odot\odot\odot$ A $\odot\odot\odot$ -SP \odot	MMTIR $\odot\odot\odot$ A \odot 16-C
American ACME		ACME	Ext.	MMT $\odot\odot\odot$ ER $\odot\odot\odot$ ACME	Wiper	MMTER $\odot\odot\odot\odot\odot\odot$ -C	G019
			Int.	MMT $\odot\odot\odot$ IR $\odot\odot\odot$ TACME	Wiper	MMTIR $\odot\odot\odot$ A $\odot\odot\odot$ -SP \odot	MMTIR $\odot\odot\odot$ A \odot 16-C
American NPT	<p> $H=0.866025P$ $h=0.800000P$ </p>	NPT	Ext.	MMT $\odot\odot\odot$ ER $\odot\odot\odot$ NPT	Wiper	MMTER $\odot\odot\odot\odot\odot\odot$ -C	G019
			Int.	MMT $\odot\odot\odot$ IR $\odot\odot\odot$ NPT	Wiper	MMTIR $\odot\odot\odot$ A $\odot\odot\odot$ -SP \odot	MMTIR $\odot\odot\odot$ A \odot 16-C

Wiper : Insert order number is determined by selected pitch.
General : An insert is applicable to several pitch types.

G

THREADING

FEATURES OF MMT SERIES

■ A WIDE VARIETY OF PRODUCTS

Mitsubishi Miracle Threading (MMT) series. 283 inserts and 26 holders.

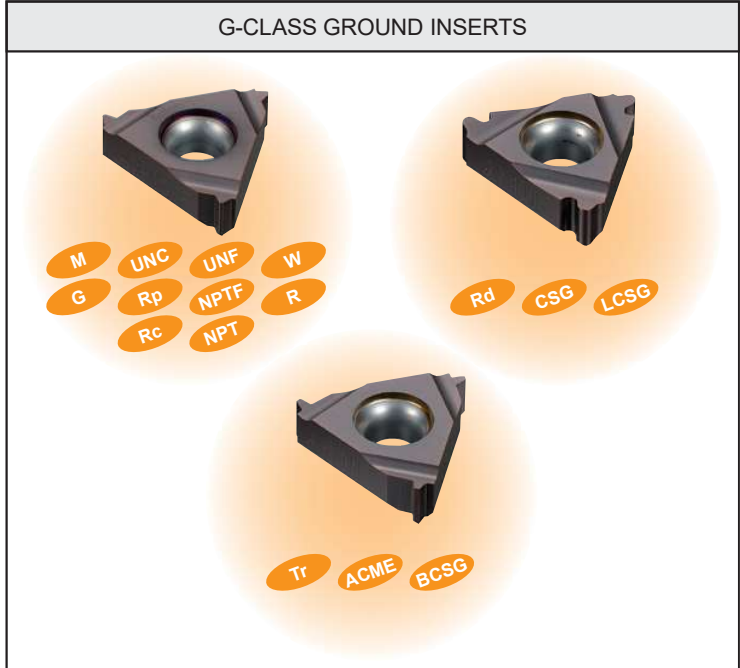
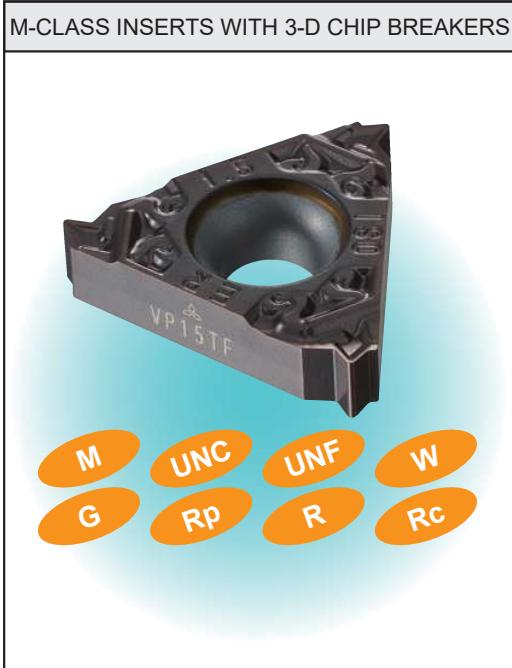

G
THREADING

■ IDEAL CHIP CONTROL EVEN IN THE LATTER HALF OF PASSES WHEN CONTINUOUS CHIPS ARE USUALLY PRODUCED. (M-CLASS INSERTS WITH 3-D CHIP BREAKERS)

ISO metric external thread pitch 1.5mm Final pass (6th pass)

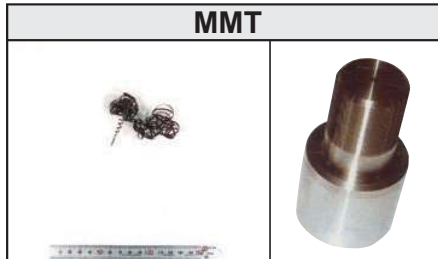
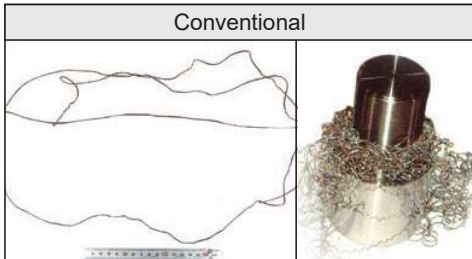

<Cutting Conditions>
 Workpiece : JIS SCM440
 Insert : MMT16ER150ISO-S
 Grade : VP15TF
 Cutting speed : 120m/min
 Cutting method : Radial Infeed
 Depth of cut : Fixed cut area
 Pass : 6 times
 Coolant : Wet

■ A HIGHER LEVEL OF PRECISION THAN CONVENTIONAL INSERTS (G-CLASS GROUND INSERTS)

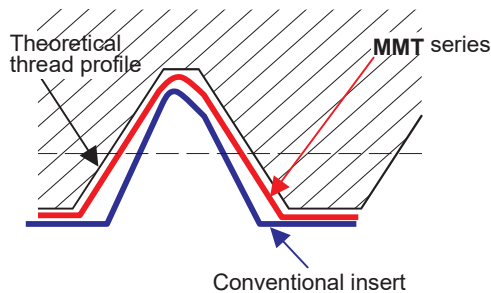

High precision threading can be achieved by using MMT inserts that feature a ground rake face and peripheral cutting edge.

Thread Type	Threading Tolerance
ISO Metric	6g / 6H
American UN	2A / 2B
Whitworth for BSW, BSP	Medium Class A
BSPT	Standard BSPT
Round DIN 405	7h / 7H
ISO Trapezoidal 30°	7e / 7H
American ACME	3G
UNJ	3A
API Buttress Casing	Standard API
API Rounded Casing & Tubing	Standard API RD
American NPT	Standard NPT
American NPTF	Class2

■ HOLDER (Use of special surface treatment)

External

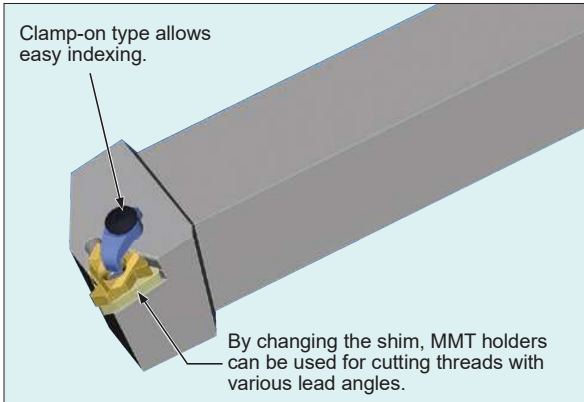

Internal

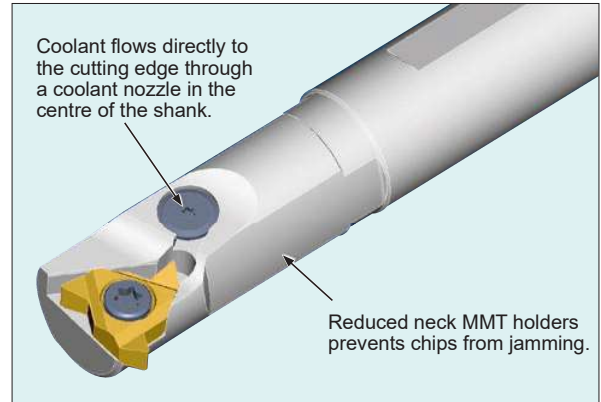

* Order number of coolant guide screw: TFS03006
(Except MMTIR1316/MMTIR1516)

■ SUITABLE FOR THREADING WITH A LARGE LEAD ANGLE

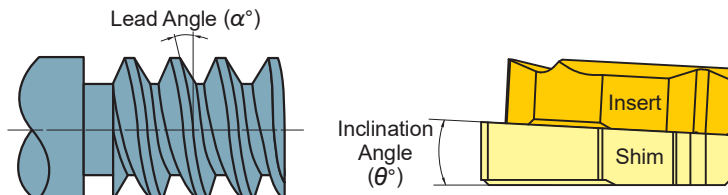

By changing only the shim, MMT holders can be used for turning of threads with various lead angles as well as the turning of left hand threads.

Lead Angle (α°)	Inclination Angle (θ°)
-1.5°	-3°
-0.5°	-2°
0.5°	-1°
1.5°	0°
2.5°	1°
3.5°	2°
4.5°	3°

Standard shim delivered with the holder.

G

THREADING

■ GRADE

VP10MF (G-class ground insert only)

● Superior wear and plastic deformation resistance

- High wear and plastic deformation resistance for threading when maintaining the thread form is important. Suitable for continuous high precision machining with extensive tool life.
- Effective in combination with G-class inserts for high precision threading.

VP15TF (G-class ground insert, M-class insert with 3-D chip breakers)

● Wide versatility

- High fracture resistance during low rigidity applications such as bar feed machining. Able to withstand harsh conditions for long periods where conventional inserts would be liable to breakage.
- Effective combination of high cost performance M-class inserts with 3-D chip breakers.

VP20RT (M-class insert with 3-D chip breakers)

● Excellent fracture resistance

- Suitable for stainless steel boring and unstable machining where inserts are vulnerable to fracturing.
- Effective combination of high cost performance M-class inserts with 3-D chip breakers.

■ CHOOSING M-CLASS INSERTS WITH 3-D CHIP BREAKERS OR G-CLASS INSERTS

Insert	Chip control	Precision of thread
M-class inserts with 3-D chip breakers 	⊙	○

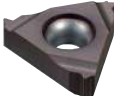
Insert	Chip control	Precision of thread
G-class inserts 	○	⊙

• For ideal chip control and a high cost performance ratio, M-class inserts with 3-D chip breakers are recommended.

• G-class inserts are recommended where higher precision is required.

CUTTING CONDITIONS OF MMT SERIES

SELECTING A SHIM FOR THE MMT SERIES

FLANK ANGLE AND LEAD ANGLE

Lead angle (α) depends on a combination of thread diameter and pitch. Select a shim so that the lead angle of the thread can coincide with the flank angles of the thread and insert (β_1, β_2). No need to change a shim for general threading with an MMT holder. When threading with a small diameter or large pitch, change the shim depending on the lead angle, referring to the table and graph below. When threading left hand threads, change to a shim with a negative inclination angle.

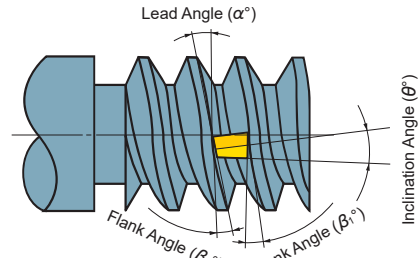

SHIM REFERENCE TABLE (THREADING DIAMETER) (Thread angle 60° and 55°)

Lead Angle Pitch (mm)	Right Hand Thread (mm)						Left Hand Thread (mm) *		
	Threading impossible	4.5°	3.5°	2.5°	1.5°	0.5°	Threading impossible	-1.5°	-0.5°
0.5	≤φ1.7	φ1.7 — φ2.3	φ2.3 — φ3.0	φ3.0 — φ4.6	φ4.6 — φ9.1	≥φ9.1	≤φ3.6	φ3.6 — φ9.1	≥φ9.1
0.75	≤φ2.5	φ2.5 — φ3.4	φ3.4 — φ4.6	φ4.6 — φ6.8	φ6.8 — φ13.7	≥φ13.7	≤φ5.5	φ5.5 — φ13.7	≥φ13.7
1	≤φ3.3	φ3.3 — φ4.6	φ4.6 — φ6.1	φ6.1 — φ9.1	φ9.1 — φ18.2	≥φ18.2	≤φ7.3	φ7.3 — φ18.2	≥φ18.2
1.25	≤φ4.1	φ4.1 — φ5.7	φ5.7 — φ7.6	φ7.6 — φ11.4	φ11.4 — φ22.8	≥φ22.8	≤φ9.1	φ9.1 — φ22.8	≥φ22.8
1.5	≤φ5.0	φ5.0 — φ6.8	φ6.8 — φ9.1	φ9.1 — φ13.7	φ13.7 — φ27.4	≥φ27.4	≤φ10.9	φ10.9 — φ27.4	≥φ27.4
1.75	≤φ5.8	φ5.8 — φ8.0	φ8.0 — φ10.6	φ10.6 — φ16.0	φ16.0 — φ31.9	≥φ31.9	≤φ12.8	φ12.8 — φ31.9	≥φ31.9
2	≤φ6.6	φ6.6 — φ9.1	φ9.1 — φ12.1	φ12.1 — φ18.2	φ18.2 — φ36.5	≥φ36.5	≤φ14.6	φ14.6 — φ36.5	≥φ36.5
2.5	≤φ8.3	φ8.3 — φ11.4	φ11.4 — φ15.2	φ15.2 — φ22.8	φ22.8 — φ45.6	≥φ45.6	≤φ18.2	φ18.2 — φ45.6	≥φ45.6
3	≤φ9.9	φ9.9 — φ13.7	φ13.7 — φ18.2	φ18.2 — φ27.3	φ27.3 — φ54.7	≥φ54.7	≤φ21.9	φ21.9 — φ54.7	≥φ54.7
3.5	≤φ11.6	φ11.6 — φ15.9	φ15.9 — φ21.3	φ21.3 — φ31.9	φ31.9 — φ63.8	≥φ63.8	≤φ25.5	φ25.5 — φ63.8	≥φ63.8
4	≤φ13.2	φ13.2 — φ18.2	φ18.2 — φ24.3	φ24.3 — φ36.5	φ36.5 — φ72.9	≥φ72.9	≤φ29.2	φ29.2 — φ72.9	≥φ72.9
4.5	≤φ14.9	φ14.9 — φ20.5	φ20.5 — φ27.3	φ27.3 — φ41.0	φ41.0 — φ82.1	≥φ82.1	≤φ32.8	φ32.8 — φ82.1	≥φ82.1
5	≤φ16.5	φ16.5 — φ22.8	φ22.8 — φ30.4	φ30.4 — φ45.6	φ45.6 — φ91.2	≥φ91.2	≤φ36.5	φ36.5 — φ91.2	≥φ91.2

* Back turning in the case of left hand threads.

SHIM REFERENCE GRAPH (Thread angle 60° and 55°)

Right Hand Thread

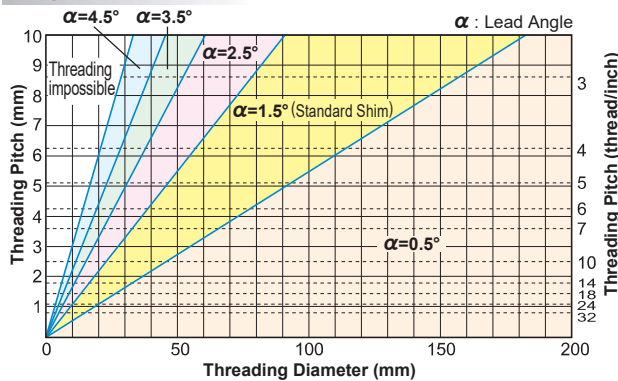

Left Hand Thread

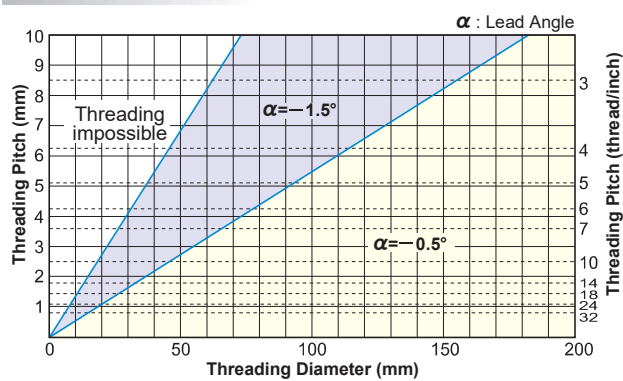

Note 1) When a thread lead angle ≤ the tool flank angle, change the shim to prevent side interference with the insert.
(Refer to the table on page G013 for the calculation of thread lead angle and tool flank angle.)

SHIM REFERENCE TABLE (THREADING DIAMETER) (Thread angle 30° and 29°)

Lead Angle Pitch (mm)	Right Hand Thread (mm)						Left Hand Thread (mm) *		
	Threading impossible	4.5°	3.5°	2.5°	1.5°	0.5°	Threading impossible	-1.5°	-0.5°
0.5	≤φ1.8	φ1.8 — φ2.3	φ2.3 — φ3.0	φ3.0 — φ4.6	φ4.6 — φ9.1	≥φ9.1	≤φ4.6	φ4.6 — φ9.1	≥φ9.1
0.75	≤φ2.7	φ2.7 — φ3.4	φ3.4 — φ4.6	φ4.6 — φ6.8	φ6.8 — φ13.7	≥φ13.7	≤φ6.8	φ6.8 — φ13.7	≥φ13.7
1	≤φ3.6	φ3.6 — φ4.6	φ4.6 — φ6.1	φ6.1 — φ9.1	φ9.1 — φ18.2	≥φ18.2	≤φ9.1	φ9.1 — φ18.2	≥φ18.2
1.25	≤φ4.5	φ4.5 — φ5.7	φ5.7 — φ7.6	φ7.6 — φ11.4	φ11.4 — φ22.8	≥φ22.8	≤φ11.4	φ11.4 — φ22.8	≥φ22.8
1.5	≤φ5.5	φ5.5 — φ6.8	φ6.8 — φ9.1	φ9.1 — φ13.7	φ13.7 — φ27.4	≥φ27.4	≤φ13.7	φ13.7 — φ27.4	≥φ27.4
1.75	≤φ6.4	φ6.4 — φ8.0	φ8.0 — φ10.6	φ10.6 — φ16.0	φ16.0 — φ31.9	≥φ31.9	≤φ16.0	φ16.0 — φ31.9	≥φ31.9
2	≤φ7.3	φ7.3 — φ9.1	φ9.1 — φ12.1	φ12.1 — φ18.2	φ18.2 — φ36.5	≥φ36.5	≤φ18.2	φ18.2 — φ36.5	≥φ36.5
2.5	≤φ9.1	φ9.1 — φ11.4	φ11.4 — φ15.2	φ15.2 — φ22.8	φ22.8 — φ45.6	≥φ45.6	≤φ22.8	φ22.8 — φ45.6	≥φ45.6
3	≤φ10.9	φ10.9 — φ13.7	φ13.7 — φ18.2	φ18.2 — φ27.3	φ27.3 — φ54.7	≥φ54.7	≤φ27.3	φ27.3 — φ54.7	≥φ54.7
3.5	≤φ12.7	φ12.7 — φ15.9	φ15.9 — φ21.3	φ21.3 — φ31.9	φ31.9 — φ63.8	≥φ63.8	≤φ31.9	φ31.9 — φ63.8	≥φ63.8
4	≤φ14.6	φ14.6 — φ18.2	φ18.2 — φ24.3	φ24.3 — φ36.5	φ36.5 — φ72.9	≥φ72.9	≤φ36.5	φ36.5 — φ72.9	≥φ72.9
4.5	≤φ16.4	φ16.4 — φ20.5	φ20.5 — φ27.3	φ27.3 — φ41.0	φ41.0 — φ82.1	≥φ82.1	≤φ41.0	φ41.0 — φ82.1	≥φ82.1
5	≤φ18.2	φ18.2 — φ22.8	φ22.8 — φ30.4	φ30.4 — φ45.6	φ45.6 — φ91.2	≥φ91.2	≤φ45.6	φ45.6 — φ91.2	≥φ91.2

* Back turning in the case of left hand threads.

G

THREADING

SHIM REFERENCE GRAPH (Thread angle 30° and 29°)

Right Hand Thread

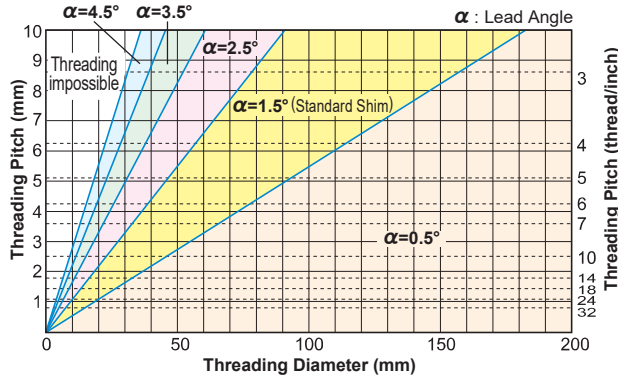

Left Hand Thread

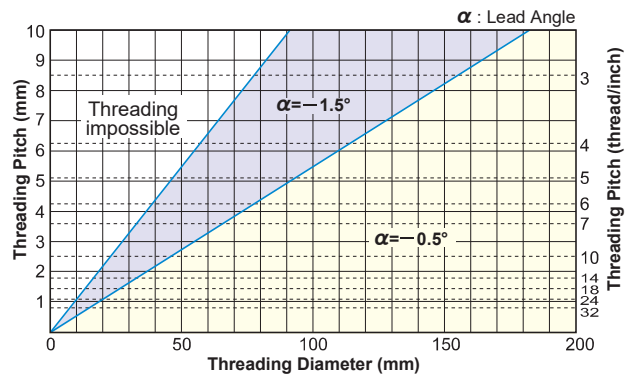

Note 1) When a thread lead angle \leq the tool flank angle, change the shim to prevent side interference with the insert.
(Refer to the table below for the calculation of thread lead angle and tool flank angle.)

Selection table

Lead Angle	Opening angle 60°/55° Right Hand Thread		Opening angle 60°/55° * Left Hand Thread		Opening angle 30°/29° Right Hand Thread		Opening angle 30°/29° * Left Hand Thread	
	P05	P05	N05	N05	P05	P05	N05	N05
0	P05	P05	N05	N05	P05	P05	N05	N05
0.5	P05	P05	N05	N05	P05	P05	N05	N05
1	P15	P15	N15	N15	P15	P15	N15	N15
1.5	P15	P15	N15	N15	P15	P15	N15	N15
2	P25	P25	N15	N15	P25	P25	Compatible	Compatible
2.5	P25	P25	Compatible	Compatible	P25	P25	Compatible	Compatible
3	P35	P35	Compatible	Compatible	P35	P35	Compatible	Compatible
3.5	P35	P35	Compatible	Compatible	P35	P35	Compatible	Compatible
4	P45	P45	Compatible	Compatible	P45	P45	Compatible	Compatible
4.5	P45	P45	Compatible	Compatible	P45	P45	Compatible	Compatible
5	P45	P45	Compatible	Compatible	Compatible	Compatible	Compatible	Compatible
5.5	Compatible	Compatible	Compatible	Compatible	Compatible	Compatible	Compatible	Compatible

* Back turning in the case of left hand threads.

When replacing a shim, check if the difference between the thread lead angle and shim inclination angle is within:
2.5°—0.5° where thread helix angle is 60° (55°)
2°—1° where thread helix angle is 30° (29°)
 * Inclination angle of a standard shim is 0°.
 * The holder has a 1.5° lead angle.

CALCULATION OF THREAD LEAD ANGLE

$$\tan \alpha = \frac{l}{\pi d} = \frac{nP}{\pi d}$$

α : Lead angle
 l : Lead
 n : Number of threads
 P : Pitch
 d : Effective diameter of thread

EXAMPLE OF SELECTING A SHIM

- When the thread lead angle is 2.2°
 - In the case when the thread helix angle is 60°
 (2.2° lead angle) — (2.5—0.5°) = -0.3°—1.7° shim inclination angle is appropriate.
 Threading with a standard shim (0° inclination angle) is possible. But, replacing with a shim with a 1° inclination angle is recommended, refer to Standard Shim List on pages G019 and G028.
 - In the case when the thread helix angle is 30°
 (2.2° lead angle) — (2—1°) = -0.2°—1.2° shim inclination angle is appropriate.
 Replacing with a shim with a 1° inclination angle is recommended, referring to Standard Shim List on pages G019 and G028.

RELIEF ANGLE OF AN INSERT SET ON A HOLDER

Thread Helix Angle	Internal Relief Angle	External Relief Angle
60°	8.8°	5.8°
55°	7.9°	5.2°
30°	4.1°	2.7°
29°	4°	2.6°

- Relief angles (β_2, β_1) of an insert become small when the thread helix angle of a trapezoidal, round, or other thread is small. Take care when selecting a shim.

* Please refer to the "Calculation of Thread Lead Angle" on the website from given QR Code.



<http://www.mitsubishicarbide.com/index.php?cid=2884>

G

THREADING

THREADING

MMT STANDARD OF DEPTH OF CUT EXTERNAL (RADIAL INFED)

ISO Metric

Pitch (mm)	Total Cutting Depth	Number of Passes														Insert Type		
		1	2	3	4	5	6	7	8	9	10	11	12	13	14	G-class ground inserts	M-class inserts with 3-D chip breakers	
0.5	0.31	0.10	0.08	0.07	0.06												MMT16ER050ISO	—
0.75	0.46	0.16	0.14	0.10	0.06												MMT16ER075ISO	—
1.0	0.61	0.18	0.15	0.12	0.10	0.06											MMT16ER100ISO	MMT16ER100ISO-S
1.25	0.77	0.19	0.17	0.14	0.11	0.10	0.06										MMT16ER125ISO	MMT16ER125ISO-S
1.5	0.92	0.22	0.21	0.17	0.14	0.12	0.06										MMT16ER150ISO	MMT16ER150ISO-S
1.75	1.07	0.22	0.21	0.16	0.13	0.11	0.09	0.09	0.06								MMT16ER175ISO	MMT16ER175ISO-S
2.0	1.23	0.24	0.23	0.17	0.16	0.14	0.12	0.11	0.06								MMT16ER200ISO	MMT16ER200ISO-S
2.5	1.53	0.26	0.23	0.19	0.17	0.15	0.13	0.12	0.11	0.11	0.06						MMT16ER250ISO	MMT16ER250ISO-S
3.0	1.84	0.27	0.25	0.20	0.18	0.16	0.14	0.13	0.12	0.12	0.11	0.10	0.06				MMT16ER300ISO	MMT16ER300ISO-S
3.5	2.15	0.33	0.30	0.24	0.21	0.18	0.17	0.15	0.14	0.14	0.12	0.11	0.06				MMT22ER350ISO	—
4.0	2.45	0.34	0.31	0.24	0.22	0.19	0.17	0.16	0.14	0.14	0.13	0.12	0.12	0.11	0.06		MMT22ER400ISO	—
4.5	2.76	0.38	0.34	0.28	0.24	0.22	0.20	0.18	0.16	0.16	0.15	0.14	0.13	0.12	0.06		MMT22ER450ISO	—
5.0	3.07	0.42	0.38	0.32	0.27	0.24	0.22	0.20	0.18	0.18	0.17	0.16	0.15	0.12	0.06		MMT22ER500ISO	—

American UN

Pitch (thread/inch)	Total Cutting Depth	Number of Passes														Insert Type		
		1	2	3	4	5	6	7	8	9	10	11	12	13	14	G-class ground inserts	M-class inserts with 3-D chip breakers	
32	0.49	0.17	0.15	0.11	0.06												MMT16ER320UN	—
28	0.56	0.17	0.14	0.10	0.09	0.06											MMT16ER280UN	—
24	0.65	0.18	0.16	0.14	0.11	0.06											MMT16ER240UN	—
20	0.78	0.20	0.18	0.13	0.11	0.10	0.06										MMT16ER200UN	—
18	0.87	0.22	0.20	0.15	0.13	0.11	0.06										MMT16ER180UN	—
16	0.97	0.22	0.20	0.15	0.12	0.11	0.11	0.06									MMT16ER160UN	MMT16ER160UN-S
14	1.11	0.23	0.21	0.16	0.13	0.11	0.11	0.10	0.06								MMT16ER140UN	MMT16ER140UN-S
13	1.20	0.25	0.22	0.17	0.14	0.13	0.12	0.11	0.06								MMT16ER130UN	—
12	1.30	0.28	0.23	0.18	0.16	0.14	0.13	0.12	0.06								MMT16ER120UN	MMT16ER120UN-S
11	1.42	0.28	0.23	0.19	0.16	0.14	0.13	0.12	0.11	0.06							MMT16ER110UN	—
10	1.56	0.28	0.24	0.19	0.16	0.14	0.13	0.13	0.12	0.11	0.06						MMT16ER100UN	—
9	1.73	0.34	0.29	0.22	0.17	0.15	0.14	0.13	0.12	0.11	0.06						MMT16ER090UN	—
8	1.95	0.35	0.30	0.24	0.19	0.16	0.15	0.14	0.13	0.12	0.11	0.06					MMT16ER080UN	—
7	2.22	0.37	0.33	0.28	0.24	0.20	0.17	0.16	0.15	0.14	0.12	0.06					MMT22ER070UN	—
6	2.60	0.42	0.35	0.29	0.25	0.21	0.18	0.17	0.16	0.15	0.13	0.12	0.11	0.06			MMT22ER060UN	—
5	3.12	0.43	0.39	0.31	0.27	0.24	0.22	0.20	0.19	0.19	0.18	0.17	0.15	0.12	0.06		MMT22ER050UN	—

Whitworth for BSW, BSP

Pitch (thread/inch)	Total Cutting Depth	Number of Passes														Insert Type		
		1	2	3	4	5	6	7	8	9	10	11	12	13	14	G-class ground inserts	M-class inserts with 3-D chip breakers	
28	0.58	0.17	0.14	0.11	0.10	0.06											MMT16ER280W	—
26	0.63	0.18	0.15	0.13	0.11	0.06											MMT16ER260W	—
20	0.81	0.20	0.18	0.14	0.12	0.11	0.06										MMT16ER200W	—
19	0.86	0.21	0.19	0.15	0.13	0.12	0.06										MMT16ER190W	MMT16ER190W-S
18	0.90	0.25	0.19	0.15	0.13	0.12	0.06										MMT16ER180W	—
16	1.02	0.21	0.18	0.15	0.13	0.11	0.09	0.09	0.06								MMT16ER160W	—
14	1.16	0.23	0.21	0.17	0.14	0.12	0.12	0.11	0.06								MMT16ER140W	MMT16ER140W-S
12	1.36	0.27	0.25	0.20	0.16	0.15	0.14	0.13	0.06								MMT16ER120W	—
11	1.48	0.27	0.24	0.20	0.17	0.15	0.14	0.13	0.12	0.06							MMT16ER110W	MMT16ER110W-S
10	1.63	0.27	0.25	0.20	0.17	0.15	0.15	0.13	0.13	0.12	0.06						MMT16ER100W	—
9	1.81	0.28	0.26	0.21	0.18	0.16	0.15	0.14	0.13	0.12	0.12	0.06					MMT16ER090W	—
8	2.03	0.30	0.27	0.22	0.19	0.17	0.16	0.15	0.14	0.13	0.12	0.12	0.06				MMT16ER080W	—
7	2.32	0.34	0.32	0.26	0.22	0.20	0.18	0.17	0.16	0.15	0.14	0.12	0.06				MMT22ER070W	—
6	2.71	0.35	0.33	0.27	0.23	0.21	0.20	0.19	0.17	0.16	0.15	0.14	0.13	0.12	0.06		MMT22ER060W	—
5	3.25	0.42	0.40	0.35	0.29	0.26	0.24	0.22	0.20	0.19	0.18	0.17	0.15	0.12	0.06		MMT22ER050W	—

BSPT

Pitch (thread/inch)	Total Cutting Depth	Number of Passes														Insert Type		
		1	2	3	4	5	6	7	8	9						G-class ground inserts	M-class inserts with 3-D chip breakers	
28	0.58	0.17	0.14	0.11	0.10	0.06											MMT16ER280BSPT	—
19	0.86	0.22	0.19	0.15	0.12	0.12	0.06										MMT16ER190BSPT	MMT16ER190BSPT-S
14	1.16	0.24	0.20	0.17	0.14	0.12	0.12	0.11	0.06								MMT16ER140BSPT	MMT16ER140BSPT-S
11	1.48	0.25	0.23	0.21	0.18	0.16	0.14	0.13	0.12	0.06							MMT16ER110BSPT	MMT16ER110BSPT-S

Note 1) • Set the finishing allowance on a diameter at approx. 0.1mm when using a full form insert.

- Please note the cutting depth and the number of passes when a corner radius of a partial form insert or of an internal threading insert is small to prevent damage to the insert corner.
- Please set the cutting depth sufficiently deep enough on materials such as hardened steel or austenitic stainless steel to help prevent premature wear and chipping caused by the outer layer of the material.

MMT STANDARD OF DEPTH OF CUT EXTERNAL (RADIAL INFED)

Round DIN 405

Pitch (thread/inch)	Total Cutting Depth	Number of Passes														Insert Type		
		1	2	3	4	5	6	7	8	9	10	11	12	13	14			
10	1.27	0.23	0.21	0.20	0.19	0.16	0.12	0.10	0.06									MMT16ER100RD
8	1.59	0.23	0.21	0.20	0.19	0.18	0.16	0.14	0.12	0.10	0.06							MMT16ER080RD
6	2.12	0.26	0.25	0.24	0.22	0.21	0.19	0.17	0.16	0.14	0.12	0.10	0.06					MMT16ER060RD
4	3.18	0.34	0.33	0.32	0.30	0.28	0.26	0.24	0.22	0.20	0.19	0.17	0.15	0.12	0.06			MMT22ER040RD

ISO Trapezoidal 30°

Pitch (mm)	Total Cutting Depth	Number of Passes														Insert Type		
		1	2	3	4	5	6	7	8	9	10	11	12	13	14			
1.5	0.90	0.23	0.21	0.16	0.13	0.11	0.06											MMT16ER150TR
2.0	1.25	0.29	0.26	0.21	0.18	0.14	0.12	0.06										MMT16ER200TR
3.0	1.75	0.32	0.31	0.24	0.19	0.18	0.17	0.15	0.13	0.06								MMT16ER300TR
4.0	2.25	0.33	0.32	0.24	0.22	0.21	0.17	0.16	0.15	0.14	0.13	0.12	0.06					MMT22ER400TR
5.0	2.75	0.35	0.32	0.26	0.24	0.22	0.21	0.19	0.19	0.17	0.15	0.14	0.13	0.12	0.06			MMT22ER500TR

American ACME

Pitch (thread/inch)	Total Cutting Depth	Number of Passes														Insert Type		
		1	2	3	4	5	6	7	8	9	10	11	12	13	14			
12	1.19	0.27	0.23	0.20	0.17	0.14	0.12	0.06										MMT16ER120ACME
10	1.52	0.29	0.25	0.21	0.18	0.16	0.14	0.12	0.11	0.06								MMT16ER100ACME
8	1.84	0.30	0.26	0.22	0.19	0.16	0.15	0.14	0.13	0.12	0.11	0.06						MMT16ER080ACME
6	2.37	0.34	0.30	0.27	0.24	0.21	0.19	0.16	0.14	0.12	0.12	0.11	0.11	0.06				MMT22ER060ACME
5	2.79	0.36	0.33	0.30	0.26	0.23	0.20	0.18	0.17	0.16	0.15	0.14	0.13	0.12	0.06			MMT22ER050ACME

UNJ

Pitch (thread/inch)	Total Cutting Depth	Number of Passes														Insert Type		
		1	2	3	4	5	6	7	8	9	10	11						
32	0.46	0.16	0.14	0.10	0.06													MMT16ER320UNJ
28	0.52	0.16	0.12	0.09	0.09	0.06												MMT16ER280UNJ
24	0.61	0.17	0.14	0.14	0.10	0.06												MMT16ER240UNJ
20	0.73	0.19	0.16	0.13	0.10	0.09	0.06											MMT16ER200UNJ
18	0.81	0.23	0.18	0.14	0.10	0.10	0.06											MMT16ER180UNJ
16	0.92	0.26	0.21	0.14	0.12	0.10	0.09											MMT16ER160UNJ
14	1.05	0.26	0.23	0.17	0.12	0.11	0.10	0.06										MMT16ER140UNJ
12	1.22	0.28	0.27	0.20	0.17	0.13	0.11	0.06										MMT16ER120UNJ
10	1.47	0.30	0.29	0.21	0.15	0.13	0.12	0.11	0.10	0.06								MMT16ER100UNJ
8	1.83	0.31	0.30	0.23	0.18	0.15	0.14	0.13	0.12	0.11	0.10	0.06						MMT16ER080UNJ

API Buttress Casing

Pitch (thread/inch)	Total Cutting Depth	Number of Passes											Insert Type					
		1	2	3	4	5	6	7	8	9	10	11						
5	1.55	0.25	0.23	0.17	0.15	0.13	0.12	0.12	0.11	0.11	0.10	0.06						MMT22ER050APBU

API Round Casing&Tubing

Pitch (thread/inch)	Total Cutting Depth	Number of Passes												Insert Type				
		1	2	3	4	5	6	7	8	9	10	11	12					
10	1.41	0.25	0.23	0.16	0.14	0.12	0.12	0.12	0.11	0.10	0.06							MMT16ER100APRD
8	1.81	0.25	0.24	0.19	0.16	0.14	0.14	0.13	0.13	0.13	0.13	0.11	0.06					MMT16ER080APRD

American NPT

Pitch (thread/inch)	Total Cutting Depth	Number of Passes															Insert Type	
		1	2	3	4	5	6	7	8	9	10	11	12	13	14	15		
27	0.66	0.15	0.13	0.12	0.11	0.09	0.06											MMT16ER270NPT
18	1.01	0.20	0.16	0.14	0.13	0.12	0.11	0.09	0.06									MMT16ER180NPT
14	1.33	0.23	0.19	0.16	0.14	0.13	0.12	0.11	0.10	0.09	0.06							MMT16ER140NPT
11.5	1.64	0.24	0.19	0.17	0.15	0.15	0.13	0.13	0.12	0.11	0.10	0.09	0.06					MMT16ER115NPT
8	2.42	0.33	0.28	0.23	0.20	0.18	0.16	0.15	0.14	0.13	0.12	0.12	0.11	0.11	0.10	0.06		MMT16ER080NPT

American NPTF

Pitch (thread/inch)	Total Cutting Depth	Number of Passes															Insert Type	
		1	2	3	4	5	6	7	8	9	10	11	12	13	14	15		
27	0.64	0.16	0.14	0.11	0.09	0.08	0.06											MMT16ER270NPTF
18	1.00	0.19	0.16	0.14	0.13	0.12	0.11	0.09	0.06									MMT16ER180NPTF
14	1.35	0.23	0.21	0.16	0.14	0.13	0.12	0.11	0.10	0.09	0.06							MMT16ER140NPTF
11.5	1.63	0.24	0.23	0.19	0.15	0.13	0.11	0.11	0.11	0.10	0.10	0.10	0.06					MMT16ER115NPTF
8	2.38	0.32	0.27	0.23	0.19	0.17	0.16	0.15	0.14	0.13	0.12	0.12	0.11	0.11	0.10	0.06		MMT16ER080NPTF

Note 1) • Set the finishing allowance on a diameter at approx. 0.1mm when using a full form insert.

- Please note the cutting depth and the number of passes when a corner radius of a partial form insert or of an internal threading insert is small to prevent damage to the insert corner.
- Please set the cutting depth sufficiently deep enough on materials such as hardened steel or austenitic stainless steel to help prevent premature wear and chipping caused by the outer layer of the material.

G

THREADING

THREADING

MMT STANDARD OF DEPTH OF CUT INTERNAL (RADIAL INFED)

ISO Metric

Pitch (mm)	Total Cutting Depth	Number of Passes														Insert Type					
		1	2	3	4	5	6	7	8	9	10	11	12	13	14	G-class ground inserts		M-class inserts with 3-D chip breakers			
0.5	0.29	0.09	0.07	0.07	0.06													MMT11R050ISO	MMT16R050ISO	—	—
0.75	0.43	0.15	0.13	0.09	0.06													MMT11R075ISO	MMT16R075ISO	—	—
1.0	0.58	0.17	0.15	0.11	0.09	0.06												MMT11R100ISO	MMT16R100ISO	MMT11R100ISO-S	MMT16R100ISO-S
1.25	0.72	0.18	0.16	0.12	0.11	0.09	0.06											MMT11R125ISO	MMT16R125ISO	MMT11R125ISO-S	MMT16R125ISO-S
1.5	0.87	0.21	0.20	0.16	0.13	0.11	0.06											MMT11R150ISO	MMT16R150ISO	MMT11R150ISO-S	MMT16R150ISO-S
1.75	1.01	0.21	0.20	0.15	0.12	0.10	0.09	0.08	0.06									MMT11R175ISO	MMT16R175ISO	—	MMT16R175ISO-S
2.0	1.15	0.24	0.22	0.18	0.14	0.12	0.10	0.09	0.06									MMT11R200ISO	MMT16R200ISO	—	MMT16R200ISO-S
2.5	1.44	0.25	0.24	0.21	0.15	0.13	0.12	0.10	0.09	0.09	0.06							—	MMT16R250ISO	—	MMT16R250ISO-S
3.0	1.73	0.26	0.25	0.22	0.17	0.14	0.13	0.12	0.11	0.10	0.09	0.08	0.06					—	MMT16R300ISO	—	MMT16R300ISO-S
3.5	2.02	0.32	0.30	0.23	0.19	0.17	0.15	0.14	0.13	0.12	0.11	0.10	0.06					—	MMT22R350ISO	—	—
4.0	2.31	0.33	0.31	0.24	0.22	0.18	0.15	0.14	0.13	0.12	0.12	0.11	0.10	0.10	0.06			—	MMT22R400ISO	—	—
4.5	2.60	0.36	0.33	0.28	0.24	0.21	0.19	0.16	0.15	0.14	0.13	0.12	0.12	0.11	0.06			—	MMT22R450ISO	—	—
5.0	2.89	0.41	0.38	0.32	0.27	0.24	0.21	0.18	0.16	0.15	0.14	0.13	0.12	0.12	0.06			—	MMT22R500ISO	—	—

American UN

Pitch (thread/inch)	Total Cutting Depth	Number of Passes														Insert Type					
		1	2	3	4	5	6	7	8	9	10	11	12	13	14	G-class ground inserts		M-class inserts with 3-D chip breakers			
32	0.46	0.16	0.14	0.10	0.06													MMT11R320UN	MMT16R320UN	—	—
28	0.52	0.16	0.13	0.09	0.08	0.06												MMT11R280UN	MMT16R280UN	—	—
24	0.61	0.17	0.15	0.13	0.10	0.06												MMT11R240UN	MMT16R240UN	—	—
20	0.73	0.18	0.15	0.13	0.11	0.10	0.06											MMT11R200UN	MMT16R200UN	—	—
18	0.81	0.20	0.18	0.14	0.12	0.11	0.06											MMT11R180UN	MMT16R180UN	—	—
16	0.92	0.20	0.18	0.15	0.12	0.11	0.10	0.06										MMT11R160UN	MMT16R160UN	MMT16R160UN-S	—
14	1.05	0.21	0.18	0.15	0.13	0.11	0.11	0.10	0.06									MMT11R140UN	MMT16R140UN	MMT16R140UN-S	—
13	1.13	0.22	0.19	0.16	0.14	0.13	0.12	0.11	0.06									—	MMT16R130UN	—	—
12	1.22	0.24	0.22	0.18	0.16	0.13	0.12	0.11	0.06									—	MMT16R120UN	MMT16R120UN-S	—
11	1.33	0.24	0.22	0.20	0.15	0.12	0.12	0.11	0.11	0.06								—	MMT16R110UN	—	—
10	1.47	0.25	0.22	0.21	0.14	0.13	0.12	0.12	0.11	0.11	0.06							—	MMT16R100UN	—	—
9	1.63	0.31	0.23	0.21	0.17	0.15	0.14	0.13	0.12	0.11	0.06							—	MMT16R090UN	—	—
8	1.83	0.31	0.26	0.21	0.18	0.16	0.15	0.14	0.13	0.12	0.11	0.06						—	MMT16R080UN	—	—
7	2.09	0.36	0.30	0.24	0.21	0.18	0.17	0.16	0.15	0.14	0.12	0.06						—	MMT22R070UN	—	—
6	2.44	0.40	0.33	0.25	0.23	0.19	0.17	0.16	0.15	0.14	0.13	0.12	0.11	0.06				—	MMT22R060UN	—	—
5	2.93	0.41	0.35	0.31	0.26	0.23	0.21	0.20	0.19	0.17	0.15	0.14	0.13	0.12	0.06			—	MMT22R050UN	—	—

Whitworth for BSW, BSP

Pitch (thread/inch)	Total Cutting Depth	Number of Passes														Insert Type					
		1	2	3	4	5	6	7	8	9	10	11	12	13	14	G-class ground inserts		M-class inserts with 3-D chip breakers			
28	0.58	0.17	0.14	0.11	0.10	0.06												—	MMT16R280W	—	—
26	0.63	0.18	0.15	0.13	0.11	0.06												—	MMT16R260W	—	—
20	0.81	0.20	0.18	0.14	0.12	0.11	0.06											—	MMT16R200W	—	—
19	0.86	0.21	0.19	0.15	0.13	0.12	0.06											MMT11R190W	MMT16R190W	MMT16R190W-S	—
18	0.90	0.25	0.19	0.15	0.13	0.12	0.06											—	MMT16R180W	—	—
16	1.02	0.21	0.18	0.15	0.13	0.11	0.09	0.09	0.06									—	MMT16R160W	—	—
14	1.16	0.23	0.21	0.17	0.14	0.12	0.12	0.11	0.06									MMT11R140W	MMT16R140W	MMT16R140W-S	—
12	1.36	0.27	0.25	0.20	0.16	0.15	0.14	0.13	0.06									—	MMT16R120W	MMT16R120W-S	—
11	1.48	0.27	0.24	0.20	0.17	0.15	0.14	0.13	0.12	0.06								—	MMT16R110W	—	—
10	1.63	0.27	0.25	0.20	0.17	0.15	0.15	0.13	0.13	0.12	0.06							—	MMT16R100W	—	—
9	1.81	0.28	0.26	0.21	0.18	0.16	0.15	0.14	0.13	0.12	0.12	0.06						—	MMT16R090W	—	—
8	2.03	0.30	0.27	0.22	0.19	0.17	0.16	0.15	0.14	0.13	0.12	0.12	0.06					—	MMT16R080W	—	—
7	2.32	0.34	0.32	0.26	0.22	0.20	0.18	0.17	0.16	0.15	0.14	0.12	0.06					—	MMT22R070W	—	—
6	2.71	0.35	0.33	0.27	0.23	0.21	0.20	0.19	0.17	0.16	0.15	0.14	0.13	0.12	0.06			—	MMT22R060W	—	—
5	3.25	0.42	0.40	0.35	0.29	0.26	0.24	0.22	0.20	0.19	0.18	0.17	0.15	0.12	0.06			—	MMT22R050W	—	—

Note 1) • Set the finishing allowance on a diameter at approx. 0.1mm when using a full form insert.

- Please note the cutting depth and the number of passes when a corner radius of a partial form insert or of an internal threading insert is small to prevent damage to the insert corner.
- Please set the cutting depth sufficiently deep enough on materials such as hardened steel or austenitic stainless steel to help prevent premature wear and chipping caused by the outer layer of the material.

MMT STANDARD OF DEPTH OF CUT INTERNAL (RADIAL INFEEED)

BSPT

Pitch (thread/ inch)	Total Cutting Depth	Number of Passes											Insert Type							
		1	2	3	4	5	6	7	8	9										
19	0.86	0.22	0.19	0.15	0.12	0.12	0.06											MMT11R190BSPT	MMT16R190BSPT	MMT16R190BSPT-S
14	1.16	0.24	0.20	0.17	0.14	0.12	0.12	0.11	0.06									MMT11R140BSPT	MMT16R140BSPT	MMT16R140BSPT-S
11	1.48	0.25	0.23	0.21	0.18	0.16	0.14	0.13	0.12	0.06								—	MMT16R110BSPT	MMT16R110BSPT-S

Round DIN 405

Pitch (thread/ inch)	Total Cutting Depth	Number of Passes														Insert Type				
		1	2	3	4	5	6	7	8	9	10	11	12	13	14					
10	1.27	0.23	0.21	0.20	0.19	0.16	0.12	0.10	0.06											MMT16R100RD
8	1.59	0.23	0.21	0.20	0.19	0.18	0.16	0.14	0.12	0.10	0.06									MMT16R080RD
6	2.12	0.26	0.25	0.24	0.22	0.21	0.19	0.17	0.16	0.14	0.12	0.10	0.06							MMT16R060RD
4	3.18	0.34	0.33	0.32	0.30	0.28	0.26	0.24	0.22	0.20	0.19	0.17	0.15	0.12	0.06					MMT22R040RD

ISO Trapezoidal 30°

Pitch (mm)	Total Cutting Depth	Number of Passes														Insert Type				
		1	2	3	4	5	6	7	8	9	10	11	12	13	14					
1.5	0.90	0.23	0.21	0.16	0.13	0.11	0.06													MMT16R150TR
2	1.25	0.29	0.26	0.21	0.17	0.14	0.12	0.06												MMT16R200TR
3	1.75	0.32	0.31	0.24	0.19	0.18	0.17	0.15	0.13	0.06										MMT16R300TR
4	2.25	0.33	0.32	0.24	0.22	0.21	0.17	0.16	0.15	0.14	0.13	0.12	0.06							MMT22R400TR
5	2.75	0.35	0.32	0.26	0.24	0.22	0.21	0.19	0.19	0.17	0.15	0.14	0.13	0.12	0.06					MMT22R500TR

American ACME

Pitch (thread/ inch)	Total Cutting Depth	Number of Passes														Insert Type				
		1	2	3	4	5	6	7	8	9	10	11	12	13	14					
12	1.19	0.27	0.23	0.20	0.17	0.14	0.12	0.06												MMT16R120ACME
10	1.52	0.29	0.25	0.21	0.18	0.16	0.14	0.12	0.11	0.06										MMT16R100ACME
8	1.84	0.30	0.26	0.22	0.19	0.16	0.15	0.14	0.13	0.12	0.11	0.06								MMT16R080ACME
6	2.37	0.34	0.30	0.27	0.24	0.21	0.19	0.16	0.14	0.12	0.12	0.11	0.11	0.06						MMT22R060ACME
5	2.79	0.36	0.33	0.30	0.26	0.23	0.20	0.18	0.17	0.16	0.15	0.14	0.13	0.12	0.06					MMT22R050ACME

API Buttress Casing

Pitch (thread/ inch)	Total Cutting Depth	Number of Passes											Insert Type							
		1	2	3	4	5	6	7	8	9	10	11								
5	1.55	0.25	0.23	0.17	0.15	0.13	0.12	0.12	0.11	0.11	0.10	0.06								MMT22R050APBU

API Round Casing&Tubing

Pitch (thread/ inch)	Total Cutting Depth	Number of Passes												Insert Type						
		1	2	3	4	5	6	7	8	9	10	11	12							
10	1.41	0.25	0.23	0.16	0.14	0.12	0.12	0.12	0.11	0.10	0.06									MMT16R100APRD
8	1.81	0.25	0.24	0.19	0.16	0.14	0.14	0.13	0.13	0.13	0.13	0.11	0.06							MMT16R080APRD

American NPT

Pitch (thread/ inch)	Total Cutting Depth	Number of Passes															Insert Type			
		1	2	3	4	5	6	7	8	9	10	11	12	13	14	15				
27	0.66	0.15	0.13	0.12	0.11	0.09	0.06													MMT16R270NPT
18	1.01	0.20	0.16	0.14	0.13	0.12	0.11	0.09	0.06											MMT16R180NPT
14	1.33	0.23	0.19	0.16	0.14	0.13	0.12	0.11	0.10	0.09	0.06									MMT16R140NPT
11.5	1.64	0.24	0.19	0.17	0.15	0.15	0.13	0.13	0.12	0.11	0.10	0.09	0.06							MMT16R115NPT
8	2.42	0.33	0.28	0.23	0.20	0.18	0.16	0.15	0.14	0.13	0.12	0.12	0.11	0.11	0.10	0.06				MMT16R080NPT

American NPTF

Pitch (thread/ inch)	Total Cutting Depth	Number of Passes															Insert Type			
		1	2	3	4	5	6	7	8	9	10	11	12	13	14	15				
14	1.35	0.23	0.21	0.16	0.14	0.13	0.12	0.11	0.10	0.09	0.06									MMT16R140NPTF
11.5	1.63	0.24	0.23	0.19	0.15	0.13	0.11	0.11	0.11	0.10	0.10	0.10	0.06							MMT16R115NPTF
8	2.38	0.32	0.27	0.23	0.19	0.17	0.16	0.15	0.14	0.13	0.12	0.12	0.11	0.11	0.10	0.06				MMT16R080NPTF

Note 1) • Set the finishing allowance on a diameter at approx. 0.1mm when using a full form insert.

- Please note the cutting depth and the number of passes when a corner radius of a partial form insert or of an internal threading insert is small to prevent damage to the insert corner.
- Please set the cutting depth sufficiently deep enough on materials such as hardened steel or austenitic stainless steel to help prevent premature wear and chipping caused by the outer layer of the material.

G

THREADING

MMT SERIES ORDER NUMBER

HOLDERS

EXTERNAL

MMT E R 12 12 H 16 - C

Designation	Application	Hand of Tool	Tool Size (mm) (Height and Width)	Tool Length (mm)	Insert Size (mm)	Method of Holding
MMT	E External	R Right	12 12 16 16 20 20 25 25 32 32	H 100 K 125 M 150 P 170	16 9.525 22 12.7	C Clamp-on

INTERNAL

MMT I R 13 16 A K 11 - S P15

Designation	Application	Min. Cutting Diameter (mm)	Shank Diameter (mm)	Hand of Tool	Shank Material	Tool Length (mm)	Insert Size (mm)	Method of Holding	Lead Angle
MMT	I Internal	13	16	R Right	A Steel Shank with Coolant Hole	K 125 R 200 M 150 S 250 Q 180 T 300	11 6.35 16 9.525 22 12.7	S Screw-on C Clamp-on	P15 1.5° P25 2.5° P35 3.5°

G

THREADING

INSERTS

M-CLASS

MMT 16 E R 100 ISO - S

Designation	Diameter of Inscribed Circle (mm)	Application	Hand of Tool	Pitch	Threading Type
MMT	11 6.35 16 9.525	E External I Internal	R Right	100 1.0mm A 0.5—1.5mm or 48—16 thread/inch 125 1.25mm 150 1.5mm G 1.75—3.0mm or 14—8 thread/inch 175 1.75mm 200 2.0mm 250 2.5mm 300 3.0mm	S M-class inserts with 3-D chip breakers 60 Partial Profile 60° 55 Partial Profile 55° ISO ISO Metric W Whitworth for BSW, BSP BSPT BSPT UN American UN

G-CLASS

MMT 16 E R 050 ISO

Designation	Diameter of Inscribed Circle (mm)	Application	Hand of Tool	Pitch	Threading Type
MMT	11 6.35 16 9.525 22 12.7	E External I Internal	R Right	050 0.5mm A 0.5—1.5mm or 48—16 thread/inch 075 0.75mm 100 1.0mm G 1.75—3.0mm or 14—8 thread/inch 125 1.25mm 150 1.5mm 175 1.75mm 200 2.0mm 250 2.5mm AG 0.5—3.0mm or 48—8 thread/inch 300 3.0mm 350 3.5mm 400 4.0mm N 3.5—5.0mm or 7—5 thread/inch 450 4.5mm 500 5.0mm	60 Partial Profile 60° 55 Partial Profile 55° ISO ISO Metric W Whitworth for BSW, BSP BSPT BSPT UN American UN RD Round DIN 405 TR ISO Trapezoidal 30° ACME American ACME UNJ UNJ APBU API Buttress Casing APRD API Round Casing&Tubing NPT NPT NPTF NPTF

MMTE HOLDER

MMTE

External threading

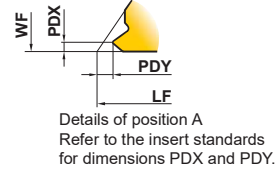
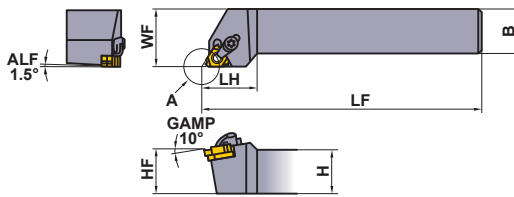
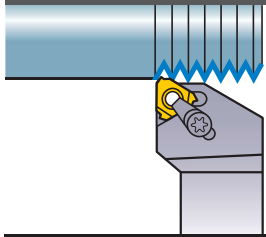

Details of position A
Refer to the insert standards
for dimensions PDX and PDY.

Right hand tool holder only.

Order Number	Stock R	Insert Number	Dimensions (mm)						Clamp Bridge	Clamp Screw *	Stop Ring	Shim Screw *	Shim	Wrench
			H	B	LF	LH	HF	WF						
MMTER1212H16-C	●	MMT16ER ○○○○○	12	12	100	25	12	16	SETK51	SETS51	CR4	HFC03008	CTE32TP15	①TKY15F ②HKY20R
MMTER1616H16-C	●		16	16	100	25	16	20	SETK51	SETS51	CR4	HFC03008	CTE32TP15	①TKY15F ②HKY20R
MMTER2020K16-C	●		20	20	125	26	20	25	SETK51	SETS51	CR4	HFC03008	CTE32TP15	①TKY15F ②HKY20R
MMTER2525M16-C	●		25	25	150	28	25	32	SETK51	SETS51	CR4	HFC03008	CTE32TP15	①TKY15F ②HKY20R
MMTER3232P16-C	●		32	32	170	32	32	40	SETK51	SETS51	CR4	HFC03008	CTE32TP15	①TKY15F ②HKY20R
MMTER2525M22-C	●	MMT22ER ○○○○○	25	25	150	32	25	32	SETK61	SETS61	CR5	HFC04010	CTE43TP15	①TKY20F ②HKY25R
MMTER3232P22-C	●		32	32	170	32	32	40	SETK61	SETS61	CR5	HFC04010	CTE43TP15	①TKY20F ②HKY25R

Note 1) Select and use a shim as shown below (sold separately), dependant on the lead angle.

* Clamp Torque (N · m) : SETS51=3.5, SETS61=5.0, HFC03008=1.5, HFC04010=2.2

SHIM

Lead Angle (α°)	Order Number	Stock R	Inclination Angle (θ°)	Applicable Holder
-1.5°	CTE32TN15	●	-3°	MMTER ○○○○○ 16-C
-0.5°	CTE32TN05	●	-2°	
0.5°	CTE32TP05	●	-1°	
1.5°	CTE32TP15	●	0°	
2.5°	CTE32TP25	●	1°	
3.5°	CTE32TP35	●	2°	
4.5°	CTE32TP45	●	3°	

Lead Angle (α°)	Order Number	Stock R	Inclination Angle (θ°)	Applicable Holder
-1.5°	CTE43TN15	●	-3°	MMTER ○○○○○ 22-C
-0.5°	CTE43TN05	●	-2°	
0.5°	CTE43TP05	●	-1°	
1.5°	CTE43TP15	●	0°	
2.5°	CTE43TP25	●	1°	
3.5°	CTE43TP35	●	2°	
4.5°	CTE43TP45	●	3°	

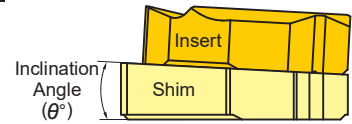

Standard shim delivered with the holder.

RECOMMENDED CUTTING CONDITIONS

	Work Material	Hardness	Grade	Cutting Speed (m/min)
P	Mild Steel	≤180HB	VP10MF	150 (70-230)
			VP15TF	100 (60-140)
			VP20RT	80 (60-100)
	Carbon Steel Alloy Steel	180-280HB	VP10MF	140 (80-200)
			VP15TF	100 (60-140)
			VP20RT	80 (60-100)
M	Stainless Steel	≤200HB	VP15TF	80 (40-120)
			VP20RT	
K	Gray Cast Iron	Tensile Strength ≤350MPa	VP10MF	140 (80-200)
			VP15TF	90 (60-120)

	Work Material	Hardness	Grade	Cutting Speed (m/min)
S	Heat-Resistant Alloy	-	VP10MF	45 (15-70)
			VP15TF	30 (20-40)
			VP20RT	
H	Titanium Alloy	-	VP10MF	60 (40-80)
			VP15TF	45 (25-65)
			VP20RT	
H	Heat-Treated Alloy	45-55HRC	VP10MF	50 (30-70)
			VP15TF	40 (20-60)

● : Inventory maintained in Japan.

HOW TO SELECT A SHIM > G012
SPARE PARTS > Q001
TECHNICAL DATA > R001

MMT M-CLASS INSERTS WITH 3-D CHIP BREAKERS

INSERTS

Type	Order Number	Coated		Pitch		Dimensions (mm)					Total Cutting Depth (mm)	Geometry
		VP15TF	VP20RT	mm	thread/inch	IC	S	PDY	PDX	RE		
Partial Profile 60°	MMT16ERA60-S	●		0.5—1.5	48—16	9.525	3.44	0.8	0.9	0.06	—	
	MMT16ERG60-S	●		1.75—3.0	14—8	9.525	3.44	1.2	1.7	0.23	—	
Partial Profile 55°	MMT16ERA55-S	●			48—16	9.525	3.44	0.8	0.9	0.07	—	
	MMT16ERG55-S	●			14—8	9.525	3.44	1.2	1.7	0.23	—	
ISO Metric	MMT16ER100ISO-S	●	●	1.0		9.525	3.44	0.7	0.7	0.13	0.61	
	MMT16ER125ISO-S	●	●	1.25		9.525	3.44	0.8	0.9	0.16	0.77	
	MMT16ER150ISO-S	●	●	1.5		9.525	3.44	0.8	1.0	0.20	0.92	
	MMT16ER175ISO-S	●	●	1.75		9.525	3.44	0.9	1.2	0.22	1.07	
	MMT16ER200ISO-S	●	●	2.0		9.525	3.44	1.0	1.3	0.26	1.23	
	MMT16ER250ISO-S	●	●	2.5		9.525	3.44	1.1	1.5	0.33	1.53	
American UN	MMT16ER160UN-S	●			16	9.525	3.44	0.9	1.1	0.23	0.97	
	MMT16ER140UN-S	●			14	9.525	3.44	1.0	1.2	0.26	1.11	
	MMT16ER120UN-S	●			12	9.525	3.44	1.1	1.4	0.30	1.30	
Whitworth for BSW, BSP	MMT16ER190W-S	●			19	9.525	3.44	0.8	1.0	0.18	0.86	
	MMT16ER140W-S	●			14	9.525	3.44	1.0	1.2	0.25	1.16	
	MMT16ER110W-S	●			11	9.525	3.44	1.1	1.5	0.32	1.48	
BSPT	MMT16ER190BSPT-S	●			19	9.525	3.44	0.8	0.9	0.18	0.86	
	MMT16ER140BSPT-S	●			14	9.525	3.44	1.0	1.2	0.25	1.16	
	MMT16ER110BSPT-S	●			11	9.525	3.44	1.1	1.5	0.32	1.48	

G
THREADING

IDENTIFICATION

MMT	16	E	R	100	ISO	-	S																																			
Designation	Diameter of Inscribed Circle (mm)	Application	Hand of Tool	Pitch	Threading Type	s M-class inserts with 3-D chip breakers																																				
	11 6.35 16 9.525	E External I Internal	R Right	<table border="1"> <tr> <td>100</td> <td>1.0mm</td> <td rowspan="2">A</td> <td rowspan="2">0.5—1.5mm or 48—16 thread/inch</td> </tr> <tr> <td>125</td> <td>1.25mm</td> </tr> <tr> <td>150</td> <td>1.5mm</td> <td rowspan="2">G</td> <td rowspan="2">1.75—3.0mm or 14—8 thread/inch</td> </tr> <tr> <td>175</td> <td>1.75mm</td> </tr> <tr> <td>200</td> <td>2.0mm</td> <td></td> <td></td> </tr> <tr> <td>250</td> <td>2.5mm</td> <td></td> <td></td> </tr> <tr> <td>300</td> <td>3.0mm</td> <td></td> <td></td> </tr> </table>	100	1.0mm	A	0.5—1.5mm or 48—16 thread/inch	125	1.25mm	150	1.5mm	G	1.75—3.0mm or 14—8 thread/inch	175	1.75mm	200	2.0mm			250	2.5mm			300	3.0mm			<table border="1"> <tr> <td>60</td> <td>Partial Profile 60°</td> </tr> <tr> <td>55</td> <td>Partial Profile 55°</td> </tr> <tr> <td>ISO</td> <td>ISO Metric</td> </tr> <tr> <td>W</td> <td>Whitworth for BSW, BSP</td> </tr> <tr> <td>BSPT</td> <td>BSPT</td> </tr> <tr> <td>UN</td> <td>American UN</td> </tr> </table>	60	Partial Profile 60°	55	Partial Profile 55°	ISO	ISO Metric	W	Whitworth for BSW, BSP	BSPT	BSPT	UN	American UN	
100	1.0mm	A	0.5—1.5mm or 48—16 thread/inch																																							
125	1.25mm																																									
150	1.5mm	G	1.75—3.0mm or 14—8 thread/inch																																							
175	1.75mm																																									
200	2.0mm																																									
250	2.5mm																																									
300	3.0mm																																									
60	Partial Profile 60°																																									
55	Partial Profile 55°																																									
ISO	ISO Metric																																									
W	Whitworth for BSW, BSP																																									
BSPT	BSPT																																									
UN	American UN																																									

● : Inventory maintained in Japan. (5 inserts in one case)

MMT G-CLASS GROUND INSERTS

INSERTS

Type	Thread Tolerance	Order Number	Coated		Pitch		Dimensions (mm)					Total Cutting Depth (mm)	Geometry	
			VP10MF	VP15TF	mm	thread/inch	IC	S	PDY	PDX	RE			
Partial Profile 60°	-	MMT16ERA60	●	●	0.5—1.5	48—16	9.525	3.44	0.8	0.9	0.05	—	Partial form PNA 60° PDX RE PDY S IC	
		MMT16ERG60	●	●	1.75—3.0	14—8	9.525	3.44	1.2	1.7	0.27			
		MMT16ERAG60	●	●	0.5—3.0	48—8	9.525	3.44	1.2	1.7	0.08			
		MMT22ERN60	●	●	3.5—5.0	7—5	12.7	4.64	1.7	2.5	0.53			
Partial Profile 55°	-	MMT16ERA55	●	●		48—16	9.525	3.44	0.8	0.9	0.05	—	Partial form PNA 55° PDX RE PDY S IC	
		MMT16ERG55	●	●		14—8	9.525	3.44	1.2	1.7	0.21			
		MMT16ERAG55	●	●		48—8	9.525	3.44	1.2	1.7	0.07			
		MMT22ERN55	●	●		7—5	12.7	4.64	1.7	2.5	0.44			
ISO Metric	6g	MMT16ER050ISO	●	●	0.5		9.525	3.44	0.6	0.4	0.06	0.31	Full form PNA 60° PDX RE PDY S IC	
		MMT16ER075ISO	●	●	0.75		9.525	3.44	0.6	0.6	0.10			0.46
		MMT16ER100ISO	●	●	1.0		9.525	3.44	0.7	0.7	0.16			0.61
		MMT16ER125ISO	●	●	1.25		9.525	3.44	0.8	0.9	0.19			0.77
		MMT16ER150ISO	●	●	1.5		9.525	3.44	0.8	1.0	0.23			0.92
		MMT16ER175ISO	●	●	1.75		9.525	3.44	0.9	1.2	0.21			1.07
		MMT16ER200ISO	●	●	2.0		9.525	3.44	1.0	1.3	0.31			1.23
		MMT16ER250ISO	●	●	2.5		9.525	3.44	1.1	1.5	0.32			1.53
		MMT16ER300ISO	●	●	3.0		9.525	3.44	1.2	1.6	0.46			1.84
		MMT22ER350ISO	●	●	3.5		12.7	4.64	1.6	2.3	0.45			2.15
		MMT22ER400ISO	●	●	4.0		12.7	4.64	1.6	2.3	0.52			2.45
		MMT22ER450ISO	●	●	4.5		12.7	4.64	1.7	2.4	0.58			2.76
		MMT22ER500ISO	●	●	5.0		12.7	4.64	1.7	2.5	0.63			3.07

G

THREADING

IDENTIFICATION

MMT 16 E R 050 ISO

Designation	Hand of Tool	Pitch	Threading Type																																																																										
<table border="1"> <tr> <th>Diameter of Inscribed Circle (mm)</th> <th></th> </tr> <tr> <td>11</td> <td>6.35</td> </tr> <tr> <td>16</td> <td>9.525</td> </tr> <tr> <td>22</td> <td>12.7</td> </tr> </table>	Diameter of Inscribed Circle (mm)		11	6.35	16	9.525	22	12.7	<table border="1"> <tr> <td>R</td> <td>Right</td> </tr> </table>	R	Right	<table border="1"> <tr> <td>050</td> <td>0.5mm</td> <td rowspan="3">A</td> <td rowspan="3">0.5—1.5mm or 48—16 thread/inch</td> </tr> <tr> <td>075</td> <td>0.75mm</td> </tr> <tr> <td>100</td> <td>1.0mm</td> </tr> <tr> <td>125</td> <td>1.25mm</td> <td rowspan="3">G</td> <td rowspan="3">1.75—3.0mm or 14—8 thread/inch</td> </tr> <tr> <td>150</td> <td>1.5mm</td> </tr> <tr> <td>175</td> <td>1.75mm</td> </tr> <tr> <td>200</td> <td>2.0mm</td> <td rowspan="3">AG</td> <td rowspan="3">0.5—3.0mm or 48—8 thread/inch</td> </tr> <tr> <td>250</td> <td>2.5mm</td> </tr> <tr> <td>300</td> <td>3.0mm</td> </tr> <tr> <td>350</td> <td>3.5mm</td> <td rowspan="3">N</td> <td rowspan="3">3.5—5.0mm or 7—5 thread/inch</td> </tr> <tr> <td>400</td> <td>4.0mm</td> </tr> <tr> <td>450</td> <td>4.5mm</td> </tr> <tr> <td>500</td> <td>5.0mm</td> <td></td> <td></td> </tr> </table>	050	0.5mm	A	0.5—1.5mm or 48—16 thread/inch	075	0.75mm	100	1.0mm	125	1.25mm	G	1.75—3.0mm or 14—8 thread/inch	150	1.5mm	175	1.75mm	200	2.0mm	AG	0.5—3.0mm or 48—8 thread/inch	250	2.5mm	300	3.0mm	350	3.5mm	N	3.5—5.0mm or 7—5 thread/inch	400	4.0mm	450	4.5mm	500	5.0mm			<table border="1"> <tr> <td>60</td> <td>Partial Profile 60°</td> </tr> <tr> <td>55</td> <td>Partial Profile 55°</td> </tr> <tr> <td>ISO</td> <td>ISO Metric</td> </tr> <tr> <td>W</td> <td>Whitworth for BSW, BSP</td> </tr> <tr> <td>BSPT</td> <td>BSPT</td> </tr> <tr> <td>UN</td> <td>American UN</td> </tr> <tr> <td>RD</td> <td>Round DIN 405</td> </tr> <tr> <td>TR</td> <td>ISO Trapezoidal 30°</td> </tr> <tr> <td>ACME</td> <td>American ACME</td> </tr> <tr> <td>UNJ</td> <td>UNJ</td> </tr> <tr> <td>APBU</td> <td>API Buttress Casing</td> </tr> <tr> <td>APRD</td> <td>API Round Casing&Tubing</td> </tr> <tr> <td>NPT</td> <td>NPT</td> </tr> <tr> <td>NPTF</td> <td>NPTF</td> </tr> </table>	60	Partial Profile 60°	55	Partial Profile 55°	ISO	ISO Metric	W	Whitworth for BSW, BSP	BSPT	BSPT	UN	American UN	RD	Round DIN 405	TR	ISO Trapezoidal 30°	ACME	American ACME	UNJ	UNJ	APBU	API Buttress Casing	APRD	API Round Casing&Tubing	NPT	NPT	NPTF	NPTF
Diameter of Inscribed Circle (mm)																																																																													
11	6.35																																																																												
16	9.525																																																																												
22	12.7																																																																												
R	Right																																																																												
050	0.5mm	A	0.5—1.5mm or 48—16 thread/inch																																																																										
075	0.75mm																																																																												
100	1.0mm																																																																												
125	1.25mm	G	1.75—3.0mm or 14—8 thread/inch																																																																										
150	1.5mm																																																																												
175	1.75mm																																																																												
200	2.0mm	AG	0.5—3.0mm or 48—8 thread/inch																																																																										
250	2.5mm																																																																												
300	3.0mm																																																																												
350	3.5mm	N	3.5—5.0mm or 7—5 thread/inch																																																																										
400	4.0mm																																																																												
450	4.5mm																																																																												
500	5.0mm																																																																												
60	Partial Profile 60°																																																																												
55	Partial Profile 55°																																																																												
ISO	ISO Metric																																																																												
W	Whitworth for BSW, BSP																																																																												
BSPT	BSPT																																																																												
UN	American UN																																																																												
RD	Round DIN 405																																																																												
TR	ISO Trapezoidal 30°																																																																												
ACME	American ACME																																																																												
UNJ	UNJ																																																																												
APBU	API Buttress Casing																																																																												
APRD	API Round Casing&Tubing																																																																												
NPT	NPT																																																																												
NPTF	NPTF																																																																												
Application																																																																													
<table border="1"> <tr> <td>E</td> <td>External</td> </tr> <tr> <td>I</td> <td>Internal</td> </tr> </table>	E	External	I	Internal																																																																									
E	External																																																																												
I	Internal																																																																												

MMT G-CLASS GROUND INSERTS

INSERTS

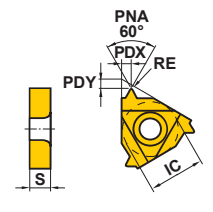
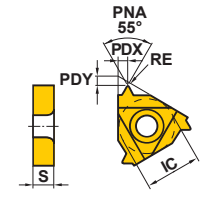
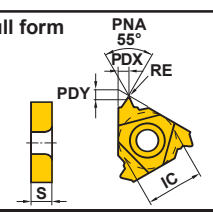
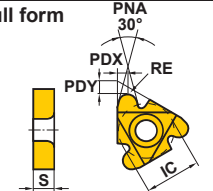
Type	Thread Tolerance	Order Number	Coated		Pitch		Dimensions (mm)					Total Cutting Depth (mm)	Geometry
			VP10MF	VP15TF	mm	thread/inch	IC	S	PDY	PDX	RE		
American UN	2A	MMT16ER320UN	●			32	9.525	3.44	0.6	0.6	0.09	0.49	Full form 
		MMT16ER280UN	●			28	9.525	3.44	0.6	0.7	0.10	0.56	
		MMT16ER240UN	●			24	9.525	3.44	0.7	0.8	0.16	0.65	
		MMT16ER200UN	●			20	9.525	3.44	0.8	0.9	0.19	0.78	
		MMT16ER180UN	●			18	9.525	3.44	0.8	1.0	0.21	0.87	
		MMT16ER160UN	●●			16	9.525	3.44	0.9	1.1	0.24	0.97	
		MMT16ER140UN	●●			14	9.525	3.44	1.0	1.2	0.22	1.11	
		MMT16ER130UN	●			13	9.525	3.44	1.0	1.3	0.24	1.20	
		MMT16ER120UN	●●			12	9.525	3.44	1.1	1.4	0.32	1.30	
		MMT16ER110UN	●			11	9.525	3.44	1.1	1.5	0.29	1.42	
		MMT16ER100UN	●			10	9.525	3.44	1.1	1.5	0.32	1.56	
		MMT16ER090UN	●			9	9.525	3.44	1.2	1.7	0.35	1.73	
		MMT16ER080UN	●			8	9.525	3.44	1.2	1.6	0.48	1.95	
		MMT22ER070UN	●			7	12.7	4.64	1.6	2.3	0.47	2.22	
		MMT22ER060UN	●			6	12.7	4.64	1.6	2.3	0.53	2.60	
MMT22ER050UN	●			5	12.7	4.64	1.7	2.5	0.64	3.12			
Whitworth for BSW, BSP	Medium Class A	MMT16ER280W	●			28	9.525	3.44	0.6	0.7	0.09	0.58	Full form 
		MMT16ER260W	●			26	9.525	3.44	0.7	0.8	0.10	0.63	
		MMT16ER200W	●			20	9.525	3.44	0.8	0.9	0.18	0.81	
		MMT16ER190W	●●			19	9.525	3.44	0.8	1.0	0.19	0.86	
		MMT16ER180W	●			18	9.525	3.44	0.8	1.0	0.20	0.90	
		MMT16ER160W	●			16	9.525	3.44	0.9	1.1	0.23	1.02	
		MMT16ER140W	●●			14	9.525	3.44	1.0	1.2	0.26	1.16	
		MMT16ER120W	●			12	9.525	3.44	1.1	1.4	0.30	1.36	
		MMT16ER110W	●●			11	9.525	3.44	1.1	1.5	0.33	1.48	
		MMT16ER100W	●			10	9.525	3.44	1.1	1.5	0.37	1.63	
		MMT16ER090W	●			9	9.525	3.44	1.2	1.7	0.34	1.81	
		MMT16ER080W	●			8	9.525	3.44	1.2	1.5	0.39	2.03	
		MMT22ER070W	●			7	12.7	4.64	1.6	2.3	0.46	2.32	
		MMT22ER060W	●			6	12.7	4.64	1.6	2.3	0.53	2.71	
		MMT22ER050W	●			5	12.7	4.64	1.7	2.4	0.66	3.25	
BSPT	Standard BSPT	MMT16ER280BSPT	●			28	9.525	3.44	0.6	0.6	0.09	0.58	Full form 
		MMT16ER190BSPT	●●			19	9.525	3.44	0.8	0.9	0.14	0.86	
		MMT16ER140BSPT	●●			14	9.525	3.44	1.0	1.2	0.26	1.16	
		MMT16ER110BSPT	●●			11	9.525	3.44	1.1	1.5	0.33	1.48	
Round DIN 405	7h	MMT16ER100RD	●			10	9.525	3.44	1.1	1.2	0.60	1.27	Full form 
		MMT16ER080RD	●			8	9.525	3.44	1.4	1.3	0.75	1.59	
		MMT16ER060RD	●			6	9.525	3.44	1.5	1.7	1.00	2.12	
		MMT22ER040RD	●			4	12.7	4.64	2.2	2.3	1.51	3.18	

G

THREADING

● : Inventory maintained in Japan. (5 inserts in one case)

Type	Thread Tolerance	Order Number	Coated VP10MF	Pitch		Dimensions (mm)					Total Cutting Depth (mm)	Geometry
				mm	thread/inch	IC	S	PDY	PDX	RE RER/L		
ISO Trapezoidal 30°	7e	MMT16ER150TR	●	1.5		9.525	3.44	1.0	1.1	0.08	0.90	Semi-full form PNA 30°
		MMT16ER200TR	●	2.0		9.525	3.44	1.1	1.3	0.15	1.25	
		MMT16ER300TR	●	3.0		9.525	3.44	1.3	1.5	0.15	1.75	
		MMT22ER400TR	●	4.0		12.7	4.64	1.7	1.9	0.15	2.25	
		MMT22ER500TR	●	5.0		12.7	4.64	2.1	2.5	0.15	2.75	
American ACME	3G	MMT16ER120ACME	●		12	9.525	3.44	1.1	1.2	0.08	1.19	Semi-full form PNA 29°
		MMT16ER100ACME	●		10	9.525	3.44	1.3	1.4	0.08	1.52	
		MMT16ER080ACME	●		8	9.525	3.44	1.4	1.5	0.10	1.84	
		MMT22ER060ACME	●		6	12.7	4.64	1.8	2.1	0.10	2.37	
		MMT22ER050ACME	●		5	12.7	4.64	2.0	2.3	0.10	2.79	
UNJ	3A	MMT16ER320UNJ	●		32	9.525	3.44	0.6	0.7	0.13	0.46	Full form
		MMT16ER280UNJ	●		28	9.525	3.44	0.7	0.7	0.14	0.52	
		MMT16ER240UNJ	●		24	9.525	3.44	0.7	0.8	0.17	0.61	
		MMT16ER200UNJ	●		20	9.525	3.44	0.8	0.9	0.20	0.73	
		MMT16ER180UNJ	●		18	9.525	3.44	0.8	1.0	0.22	0.81	
		MMT16ER160UNJ	●		16	9.525	3.44	0.9	1.1	0.25	0.92	
		MMT16ER140UNJ	●		14	9.525	3.44	1.0	1.2	0.29	1.05	
		MMT16ER120UNJ	●		12	9.525	3.44	1.1	1.3	0.33	1.22	
		MMT16ER100UNJ	●		10	9.525	3.44	1.2	1.5	0.40	1.47	
MMT16ER080UNJ	●		8	9.525	3.44	1.2	1.6	0.51	1.83			
API Buttress Casing	Standard API	MMT22ER050APBU	●		5	12.7	4.64	3.1	1.9	0.74/0.18	1.55	Full form
API Round Casing & Tubing	Standard API RD	MMT16ER100APRD	●		10	9.525	3.44	1.2	1.4	0.34	1.41	Full form
		MMT16ER080APRD	●		8	9.525	3.44	1.3	1.5	0.41	1.81	
American NPT	Standard NPT	MMT16ER270NPT	●		27	9.525	3.44	0.7	0.8	0.04	0.66	Full form
		MMT16ER180NPT	●		18	9.525	3.44	0.8	1.0	0.08	1.01	
		MMT16ER140NPT	●		14	9.525	3.44	0.9	1.2	0.09	1.33	
		MMT16ER115NPT	●		11.5	9.525	3.44	1.1	1.5	0.11	1.64	
		MMT16ER080NPT	●		8	9.525	3.44	1.3	1.8	0.14	2.42	
American NPTF	Class 2	MMT16ER270NPTF	●		27	9.525	3.44	0.7	0.8	0.04	0.64	Full form
		MMT16ER180NPTF	●		18	9.525	3.44	0.8	1.0	0.04	1.00	
		MMT16ER140NPTF	●		14	9.525	3.44	0.9	1.2	0.04	1.35	
		MMT16ER115NPTF	●		11.5	9.525	3.44	1.1	1.5	0.04	1.63	
		MMT16ER080NPTF	●		8	9.525	3.44	1.3	1.8	0.04	2.38	



THREADING

THREADING

MT HOLDER

- Clamp-on type.
- Positive insert suffers from negligible chattering and thus produces good finished surfaces.
- Thread pitch $\leq 4.5\text{mm}$.

MTH

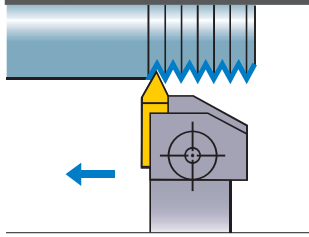

External threading

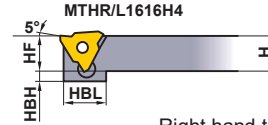
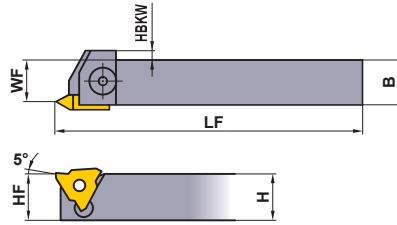

Right hand tool holder shown.

Note 1) Cutting in the opposite direction is not possible.

Order Number	Stock		Insert Number	Dimensions (mm)							Clamp Bridge	Clamp Screw *	Spring	Wrench	
	R	L		H	B	LF	HF	HBH	HBL	WF					HBKW
MTHR/L1616H4	●	●	MTTR/L43	16	16	100	16	3	21	13.8	3	MTK1R/L	HBH06020	MES3	HKY40R
MTHR/L2020K4	●	●		20	20	125	20	—	—	17.8	—	MTK1R/L	HBH06020	MES3	HKY40R
MTHR/L2525M4	●	●		25	25	150	25	—	—	22.8	—	MTK1R/L	HBH06020	MES3	HKY40R

* Clamp Torque (N · m) : HBH06020=7.0

G

THREADING

MT1

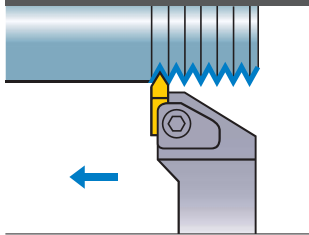

External threading

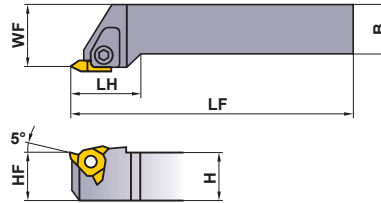

Right hand tool holder shown.

Note 1) Cutting in the opposite direction is not possible.

Order Number	Stock		Insert Number	Dimensions (mm)							Clamp Bridge	Clamp Screw *	Spring	Wrench
	R	L		H	B	LF	LH	HF	WF					
MT1R/L2020K4	●	●	MTTR/L43	20	20	125	30	20	25	MTK1R/L	HBH06020	MES3	HKY40R	
MT1R/L2525M4	●	●		25	25	150	30	25	32	MTK1R/L	HBH06020	MES3	HKY40R	
MT1R/L3232P4	●	●		32	32	170	30	32	40	MTK1R/L	HBH06020	MES3	HKY40R	

* Clamp Torque (N · m) : HBH06020=7.0

RECOMMENDED CUTTING CONDITIONS

Work Material	Hardness	Grade	Cutting Speed (m/min)
P Mild Steel	$\leq 180\text{HB}$	UP20M	140 (100—180)
		NX2525	200 (150—250)
		UTi20T	120 (100—150)
Carbon Steel Alloy Steel	180—280HB	UP20M	120 (100—150)
		NX2525	170 (150—200)
		UTi20T	100 (70—120)

Work Material	Hardness	Grade	Cutting Speed (m/min)
M Stainless Steel	$\leq 200\text{HB}$	UP20M	120 (80—150)
		UTi20T	100 (70—130)
K Gray Cast Iron	Tensile Strength $\leq 350\text{MPa}$	UP20M	80 (60—100)
		UTi20T	80 (60—100)
		HTi10	100 (70—130)

● : Inventory maintained in Japan. □ : Non stock, produced to order only.
(10 inserts in one case)

INSERTS

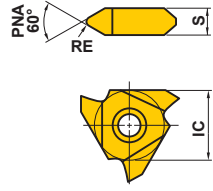
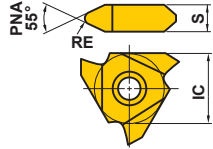
Type	Order Number	Class	Coated				ISO Pitch mm (thread/inch)	Dimensions (mm)			Geometry
			UP20M	Cermet	Carbide			IC	S	RE	
Partial Profile 60°	MTTR436000	G		●			-0.8	12.7	4.76	0	MTTR/L(60°)  Right hand insert shown.
	MTTR436001	G	●	●	●	●	1.0-1.75	12.7	4.76	0.1	
	MTTL436001	G	●			●	1.0-1.75	12.7	4.76	0.1	
	MTTR436002	G	●	●		●	2.0-2.5	12.7	4.76	0.2	
	MTTL436002	G		●		●	2.0-2.5	12.7	4.76	0.2	
	MTTR436003	G	□	●		●	3.0-3.5	12.7	4.76	0.3	
	MTTL436003	G		●		●	3.0-3.5	12.7	4.76	0.3	
	MTTR436004	G		●		●	4.0-4.5	12.7	4.76	0.4	
Partial Profile 55°	MTTR435501	G		●			(28-10)	12.7	4.76	0.1	MTTR(55°)  Right hand insert only.
	MTTR435502	G		●			(16-8)	12.7	4.76	0.2	
	MTTR435503	G		●			(11-8)	12.7	4.76	0.3	

STANDARD OF DEPTH OF CUT

- The chart on the right shows the cutting depths when machining external ISO metric screw threads.
- When you use cermet grades or cut stainless steel, please increase the number of passes by 2-3 times.

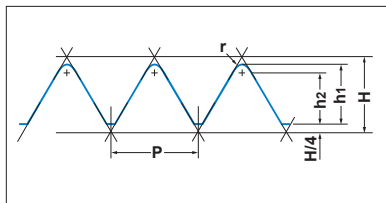

METRIC SCREW THREAD

P (Pitch)	0.75	1.00	1.25	1.50	1.75	2.00	2.50	3.00	3.50	4.00	4.50	
h1	0.46	0.61	0.77	0.92	1.07	1.23	1.53	1.84	2.15	2.45	2.76	
h2	0.35	0.47	0.59	0.70	0.82	0.94	1.17	1.41	1.65	1.87	2.11	
r (Corner Radius)	0.11	0.14	0.18	0.22	0.25	0.29	0.36	0.43	0.50	0.58	0.65	
Number of Passes	1	0.18	0.20	0.20	0.25	0.25	0.25	0.30	0.30	0.35	0.35	0.40
	2	0.13	0.15	0.18	0.20	0.20	0.25	0.25	0.25	0.30	0.30	0.35
	3	0.10	0.10	0.12	0.15	0.20	0.20	0.20	0.25	0.25	0.25	0.30
	4	0.05	0.10	0.12	0.15	0.15	0.15	0.20	0.20	0.20	0.25	0.25
	5		0.06	0.10	0.10	0.12	0.15	0.15	0.20	0.20	0.25	0.25
	6			0.05	0.07	0.10	0.10	0.10	0.15	0.20	0.20	0.20
	7					0.05	0.08	0.10	0.15	0.15	0.20	0.20
	8						0.05	0.10	0.10	0.15	0.15	0.15
	9							0.08	0.10	0.10	0.15	0.15
	10							0.05	0.09	0.10	0.10	0.15
	11								0.05	0.10	0.10	0.10
	12									0.05	0.10	0.10
	13										0.05	0.10
	14											0.06

Note 1) The first pass causes a high load on the cutting edge. In order to avoid damage, keep the depth of cut to 0.4-0.5mm maximum.



THREADING

THREADING

SMG HOLDER

- Screw-on type.
- Positive insert suffers from negligible chattering.
- Suitable for narrow grooving and threading.
- Thread pitch ≤ 2.0 mm.

SMGH

External threading, Grooving

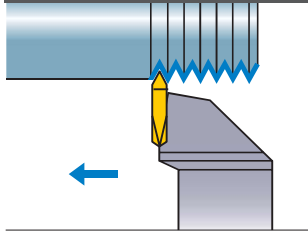

Note 1) Cutting in the opposite direction is not possible.

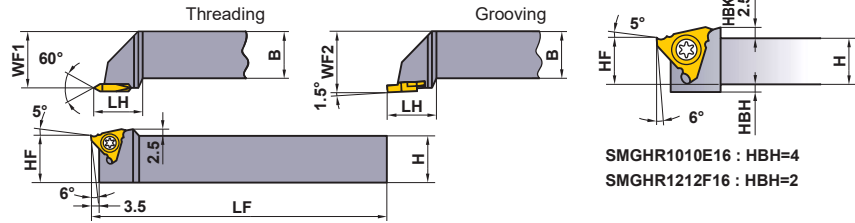

Right hand tool holder only.

Order Number	Stock	Insert Number		Dimensions (mm)							Clamp Screw *	Wrench
		Threading	Grooving	H	B	LF	LH	HF	WF1	WF2		
SMGHR1010E16	●			10	10	70	16.5	10	11.7	12	FC400890T	TKY10F
SMGHR1212F16	●			12	12	80	16.5	12	15.7	16	FC400890T	TKY10F
SMGHR1616H16	●	SMTTR160360	SMGTR16X2 SMGTR16X2C	16	16	100	20	16	19.7	20	FC400890T	TKY10F
SMGHR2020K16	●			20	20	125	20	20	24.7	25	FC400890T	TKY10F
SMGHR2525M16	●			25	25	150	20	25	31.7	32	FC400890T	TKY10F

* Clamp Torque (N · m) : FC400890T=2.5

G

THREADING

STANDARD OF DEPTH OF CUT

- The chart on the right shows the cutting depths when machining external ISO metric screw threads.
- When you use cermet grades or cut stainless steel, please increase the number of passes by 2—3 times.

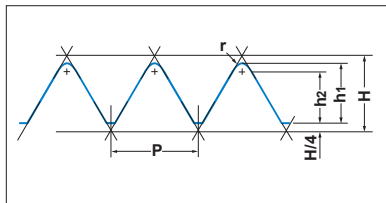

METRIC SCREW THREAD

P (Pitch)		0.75	1.00	1.25	1.50	1.75	2.00
h1		0.46	0.61	0.77	0.92	1.07	1.23
h2		0.35	0.47	0.59	0.70	0.82	0.94
r (Corner Radius)		0.11	0.14	0.18	0.22	0.25	0.29
Number of Passes	1	0.18	0.20	0.20	0.25	0.25	0.25
	2	0.13	0.15	0.18	0.20	0.20	0.25
	3	0.10	0.10	0.12	0.15	0.20	0.20
	4	0.05	0.10	0.12	0.15	0.15	0.15
	5		0.06	0.10	0.10	0.12	0.15
	6			0.05	0.07	0.10	0.10
	7					0.05	0.08
	8						0.05
	9						

Note 1) The first pass causes a high load on the cutting edge. In order to avoid damage, keep the depth of cut to 0.4—0.5mm maximum.

RECOMMENDED CUTTING CONDITIONS

Work Material	Hardness	Grade	Cutting Speed (m/min)
P Mild Steel	≤ 180 HB	NX2525	200 (150—250)
		UTi20T	120 (100—150)
Carbon Steel Alloy Steel	180—280HB	NX2525	170 (150—200)
		UTi20T	100 (70—120)

Work Material	Hardness	Grade	Cutting Speed (m/min)
M Stainless Steel	≤ 200 HB	UTi20T	100 (70—130)
K Gray Cast Iron	Tensile Strength ≤ 350 MPa	UTi20T	80 (60—100)
		HTi10	100 (70—130)

● : Inventory maintained in Japan. (10 inserts in one case)

Conditions when Inserts are Installed

Note 1) When threaded inserts are installed on the body, the height difference between the insert and body will be as shown in the following table.

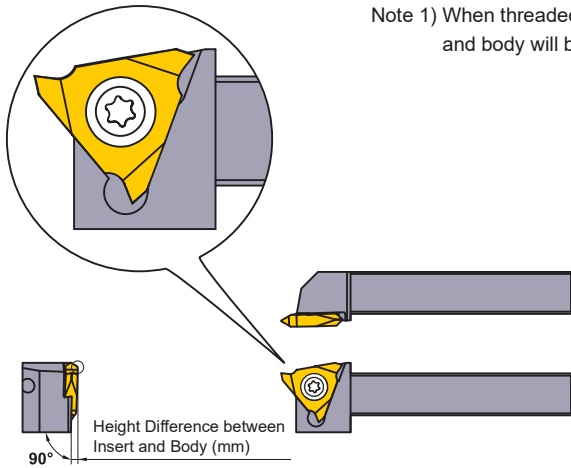

Height Difference between Insert and Body (mm)

Threading	Grooving
1.23	0.05

SMT INSERTS (Threading)

Order Number	Carbide		Thread Pitch (mm)	Dimensions (mm)			Geometry
	UTi20T			IC	S	RE	
SMTTR16036001	●		1.0—1.5	9.525	3.18	0.1	
SMTTR16036002	●		1.75—2.0	9.525	3.18	0.2	

G

THREADING

SMG INSERTS (Grooving)

Order Number	Cermet Carbide			Dimensions (mm)					Geometry
	NX2525	UTi20T	HTi10	CW	CDX	IC	S	BCH	
SMGTR16X2050		●		0.5	1.5	9.525	2	—	
SMGTR16X2060	●	●	●	0.6	1.5	9.525	2	—	
SMGTR16X2050C	●	●	●	0.5	1.5	9.525	2	0.05	
SMGTR16X2060C	●	●	●	0.6	1.5	9.525	2	0.05	
SMGTR16X2070C	●	●	●	0.7	2	9.525	2	0.05	
SMGTR16X2075C	●	●	●	0.75	2	9.525	2	0.05	
SMGTR16X2080C	●	●	●	0.8	2	9.525	2	0.1	
SMGTR16X2090C	●	●	●	0.9	2	9.525	2	0.1	
SMGTR16X2095C	●	●	●	0.95	2	9.525	2	0.1	
SMGTR16X2100C	●	●	●	1	2.5	9.525	2	0.1	
SMGTR16X2110C	●	●	●	1.1	2.5	9.525	2	0.1	
SMGTR16X2120C	●	●	●	1.2	2.5	9.525	2	0.1	
SMGTR16X2130C	●	●	●	1.3	2.5	9.525	2	0.1	

Note 1) Please refer to the page F118 for cutting conditions of grooving.

MMTI TYPE BORING BARS

MMTI

Internal threading

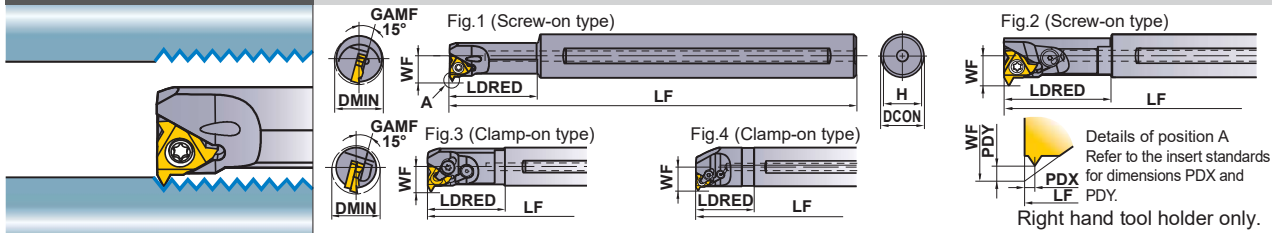

Order Number	Stock R	Insert Number	Lead Angle	Dimensions (mm)					DCON	Clamp Bridge	Clamp Screw *	Stop Ring	① Shim Screw ② Embedded Seal Screw	Shim	Wrench	Fig
				LF	LDRED	WF	H	DMIN								
MMTIR1316AK11-SP15	●	MMT11IR	1.5°	16	125	25	8.7	15	13	—	TS25	—	—	—	①TKY08F	1
MMTIR1316AK11-SP25	●		2.5°	16	125	25	8.7	15	13	—	TS25	—	—	—	①TKY08F	1
MMTIR1316AK11-SP35	●		3.5°	16	125	25	8.7	15	13	—	TS25	—	—	—	①TKY08F	1
MMTIR1516AM11-SP15	●	MMT16IR	1.5°	16	150	32	9.7	15	15	—	TS25	—	—	—	①TKY08F	1
MMTIR1516AM11-SP25	●		2.5°	16	150	32	9.7	15	15	—	TS25	—	—	—	①TKY08F	1
MMTIR1516AM11-SP35	●		3.5°	16	150	32	9.7	15	15	—	TS25	—	—	—	①TKY08F	1
MMTIR1916AM16-SP15	●	MMT22IR	1.5°	16	150	40	12.2	15	19	—	CS350860T	—	—	—	①TKY15F	2
MMTIR1916AM16-SP25	●		2.5°	16	150	40	12.2	15	19	—	CS350860T	—	—	—	①TKY15F	2
MMTIR1916AM16-SP35	●		3.5°	16	150	40	12.2	15	19	—	CS350860T	—	—	—	①TKY15F	2
MMTIR2420AQ16-C	●	MMT22IR	1.5°	20	180	40	14.2	19	24	SETK51	SETS51	CR4	①HFC03006 ②TFS03006	CTI32TP15	①TKY15F ②HKY20R	3
MMTIR2925AS16-C	●		1.5°	25	250	60	16.7	23.4	29	SETK51	SETS51	CR4	①HFC03006 ②TFS03006	CTI32TP15	①TKY15F ②HKY20R	3
MMTIR3732AS16-C	●		1.5°	32	250	48	20.5	30.4	37	SETK51	SETS51	CR4	①HFC03006 ②TFS03006	CTI32TP15	①TKY15F ②HKY20R	4
MMTIR2420AQ22-SP15	●	MMT22IR	1.5°	20	180	50	15.5	19	24	—	TS43	—	—	—	①TKY15F	2
MMTIR2420AQ22-SP25	●		2.5°	20	180	50	15.5	19	24	—	TS43	—	—	—	①TKY15F	2
MMTIR2420AQ22-SP35	●		3.5°	20	180	50	15.5	19	24	—	TS43	—	—	—	①TKY15F	2
MMTIR3025AR22-C	●	MMT22IR	1.5°	25	200	38	17.8	23.4	30	SETK61	SETS61	CR5	①HFC04008 ②TFS03006	CTI43TP15	①TKY20F ②HKY25R	4
MMTIR3832AS22-C	●		1.5°	32	250	48	21.8	30.4	38	SETK61	SETS61	CR5	①HFC04008 ②TFS03006	CTI43TP15	①TKY20F ②HKY25R	4
MMTIR4640AT22-C	●		1.5°	40	300	60	26.2	38	46	SETK61	SETS61	CR5	①HFC04008 ②TFS03006	CTI43TP15	①TKY20F ②HKY25R	4

Note) Select and use a shim as shown below (sold separately), dependant on the lead angle.

- A screw-on tool holder uses no shim. (The holder body has a lead angle.) Use a tool holder with the appropriate lead angle.
- Min. cutting diameter (DMIN) shows the internal hole diameter, not the thread diameter.

* Clamp Torque (N · m) : TS25=1.0, CS350860T=3.5, SETS51=3.5, TS43=3.5, SETS61=5.0, HFC03006=1.5, HFC04008=2.2

SHIM

Lead Angle (α°)	Order Number	Stock R	Inclination Angle (θ°)	Applicable Holder
-1.5°	CTI32TN15	●	-3°	MMTIR ○16-C
-0.5°	CTI32TN05	●	-2°	
0.5°	CTI32TP05	●	-1°	
1.5°	CTI32TP15	●	0°	
2.5°	CTI32TP25	●	1°	
3.5°	CTI32TP35	●	2°	
4.5°	CTI32TP45	●	3°	

Lead Angle (α°)	Order Number	Stock R	Inclination Angle (θ°)	Applicable Holder
-1.5°	CTI43TN15	●	-3°	MMTIR ○22-C
-0.5°	CTI43TN05	●	-2°	
0.5°	CTI43TP05	●	-1°	
1.5°	CTI43TP15	●	0°	
2.5°	CTI43TP25	●	1°	
3.5°	CTI43TP35	●	2°	
4.5°	CTI43TP45	●	3°	

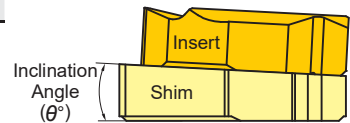

Standard shim delivered with the holder.

RECOMMENDED CUTTING CONDITIONS

Work Material	Hardness	Grade	Cutting Speed (m/min)
P Mild Steel	≤180HB	VP10MF	150 (70-230)
		VP15TF	100 (60-140)
		VP20RT	80 (60-100)
	180-280HB	VP10MF	140 (80-200)
		VP15TF	100 (60-140)
		VP20RT	80 (60-100)
M Stainless Steel	≤200HB	VP15TF VP20RT	80 (40-120)
K Gray Cast Iron	Tensile Strength ≤350MPa	VP10MF VP15TF	140 (80-200) 90 (60-120)

Work Material	Hardness	Grade	Cutting Speed (m/min)
S Heat-Resistant Alloy	—	VP10MF	45 (15-70)
		VP15TF	30 (20-40)
		VP20RT	—
Titanium Alloy	—	VP10MF	60 (40-80)
		VP15TF	45 (25-65)
		VP20RT	—
H Heat-Treated Alloy	45-55HRC	VP10MF VP15TF	50 (30-70) 40 (20-60)

● : Inventory maintained in Japan. (5 inserts in one case)

HOW TO SELECT A SHIM > G012
MMT SERIES ORDER NUMBER > G018

MMT M-CLASS INSERTS WITH 3-D CHIP BREAKERS

INSERTS

Type	Order Number	Coated		Pitch		Dimensions (mm)					Total Cutting Depth (mm)	Geometry
		VP15TF	VP20RT	mm	thread/inch	IC	S	PDY	PDX	RE		
Partial Profile 60°	MMT11IRA60-S	●		0.5—1.5	48—16	6.35	3.04	0.8	0.9	0.03	—	
	MMT16IRA60-S	●		0.5—1.5	48—16	9.525	3.44	0.8	0.9	0.03	—	
	MMT16IRG60-S	●		1.75—3.0	14—8	9.525	3.44	1.2	1.7	0.11	—	
Partial Profile 55°	MMT11IRA55-S	●			48—16	6.35	3.04	0.8	0.9	0.07	—	
	MMT16IRA55-S	●			48—16	9.525	3.44	0.8	0.9	0.07	—	
	MMT16IRG55-S	●			14—8	9.525	3.44	1.2	1.7	0.21	—	
ISO Metric	MMT11R100ISO-S	●		1.0		6.35	3.04	0.6	0.7	0.06	0.58	
	MMT11R125ISO-S	●		1.25		6.35	3.04	0.8	0.9	0.08	0.72	
	MMT11R150ISO-S	●		1.5		6.35	3.04	0.8	1.0	0.10	0.87	
	MMT16R100ISO-S	●	●	1.0		9.525	3.44	0.6	0.7	0.06	0.58	
	MMT16R125ISO-S	●	●	1.25		9.525	3.44	0.8	0.9	0.08	0.72	
	MMT16R150ISO-S	●	●	1.5		9.525	3.44	0.8	1.0	0.10	0.87	
	MMT16R175ISO-S	●	●	1.75		9.525	3.44	0.9	1.2	0.11	1.01	
	MMT16R200ISO-S	●	●	2.0		9.525	3.44	1.0	1.3	0.13	1.15	
	MMT16R250ISO-S	●	●	2.5		9.525	3.44	1.1	1.5	0.17	1.44	
MMT16R300ISO-S	●	●	3.0		9.525	3.44	1.1	1.5	0.20	1.73		
American UN	MMT16R160UN-S	●			16	9.525	3.44	0.9	1.1	0.11	0.92	
	MMT16R140UN-S	●			14	9.525	3.44	0.9	1.2	0.12	1.05	
	MMT16R120UN-S	●			12	9.525	3.44	1.1	1.4	0.14	1.22	
Whitworth for BSW, BSP	MMT16R190W-S	●			19	9.525	3.44	0.8	1.0	0.18	0.86	
	MMT16R140W-S	●			14	9.525	3.44	1.0	1.2	0.25	1.16	
	MMT16R110W-S	●			11	9.525	3.44	1.1	1.5	0.32	1.48	
BSPT	MMT16R190BSPT-S	●			19	9.525	3.44	0.8	0.9	0.18	0.86	
	MMT16R140BSPT-S	●			14	9.525	3.44	1.0	1.2	0.25	1.16	
	MMT16R110BSPT-S	●			11	9.525	3.44	1.1	1.5	0.32	1.48	

G

THREADING

IDENTIFICATION

MMT	16	I	R	100	ISO	- S																																					
Designation	Diameter of Inscribed Circle (mm)	Application	Hand of Tool	Pitch	Threading Type	M-class inserts with 3-D chip breakers																																					
	<table border="1" style="width: 100%; border-collapse: collapse;"> <tr><td>11</td><td>6.35</td></tr> <tr><td>16</td><td>9.525</td></tr> </table>	11	6.35	16	9.525	<table border="1" style="width: 100%; border-collapse: collapse;"> <tr><td>E</td><td>External</td></tr> <tr><td>I</td><td>Internal</td></tr> </table>	E	External	I	Internal	<table border="1" style="width: 100%; border-collapse: collapse;"> <tr><td>R</td><td>Right</td></tr> </table>	R	Right	<table border="1" style="width: 100%; border-collapse: collapse;"> <tr><td>100</td><td>1.0mm</td></tr> <tr><td>125</td><td>1.25mm</td></tr> <tr><td>150</td><td>1.5mm</td></tr> <tr><td>175</td><td>1.75mm</td></tr> <tr><td>200</td><td>2.0mm</td></tr> <tr><td>250</td><td>2.5mm</td></tr> <tr><td>300</td><td>3.0mm</td></tr> </table>	100	1.0mm	125	1.25mm	150	1.5mm	175	1.75mm	200	2.0mm	250	2.5mm	300	3.0mm	<table border="1" style="width: 100%; border-collapse: collapse;"> <tr><td>60</td><td>Partial Profile 60°</td></tr> <tr><td>55</td><td>Partial Profile 55°</td></tr> <tr><td>ISO</td><td>ISO Metric</td></tr> <tr><td>W</td><td>Whitworth for BSW, BSP</td></tr> <tr><td>BSPT</td><td>BSPT</td></tr> <tr><td>UN</td><td>American UN</td></tr> </table>	60	Partial Profile 60°	55	Partial Profile 55°	ISO	ISO Metric	W	Whitworth for BSW, BSP	BSPT	BSPT	UN	American UN		
11	6.35																																										
16	9.525																																										
E	External																																										
I	Internal																																										
R	Right																																										
100	1.0mm																																										
125	1.25mm																																										
150	1.5mm																																										
175	1.75mm																																										
200	2.0mm																																										
250	2.5mm																																										
300	3.0mm																																										
60	Partial Profile 60°																																										
55	Partial Profile 55°																																										
ISO	ISO Metric																																										
W	Whitworth for BSW, BSP																																										
BSPT	BSPT																																										
UN	American UN																																										

MMT G-CLASS GROUND INSERTS

INSERTS

Type	Thread Tolerance	Order Number	Coated		Pitch		Dimensions (mm)					Total Cutting Depth (mm)	Geometry
			VP10MF	VP15TF	mm	thread/inch	IC	S	PDY	PDX	RE		
Partial Profile 60°	—	MMT11IRA60	●	●	0.5—1.5	48—16	6.35	3.04	0.8	0.9	0.05	—	
		MMT16IRA60	●	●	0.5—1.5	48—16	9.525	3.44	0.8	0.9	0.05	—	
		MMT16IRG60	●	●	1.75—3.0	14—8	9.525	3.44	1.2	1.7	0.16	—	
		MMT16IRAG60	●	●	0.5—3.0	48—8	9.525	3.44	1.2	1.7	0.05	—	
		MMT22IRN60	●	●	3.5—5.0	7—5	12.7	4.64	1.7	2.5	0.30	—	
Partial Profile 55°	—	MMT11IRA55	●	●		48—16	6.35	3.04	0.8	0.9	0.05	—	
		MMT16IRA55	●	●		48—16	9.525	3.44	0.8	0.9	0.05	—	
		MMT16IRG55	●	●		14—8	9.525	3.44	1.2	1.7	0.21	—	
		MMT16IRAG55	●	●		48—8	9.525	3.44	1.2	1.7	0.07	—	
		MMT22IRN55	●	●		7—5	12.7	4.64	1.7	2.5	0.44	—	
ISO Metric	6H	MMT11IR050ISO	●	●	0.5		6.35	3.04	0.6	0.4	0.03	0.29	
		MMT11IR075ISO	●	●	0.75		6.35	3.04	0.6	0.6	0.04	0.43	
		MMT11IR100ISO	●	●	1.0		6.35	3.04	0.6	0.7	0.10	0.58	
		MMT11IR125ISO	●	●	1.25		6.35	3.04	0.8	0.9	0.12	0.72	
		MMT11IR150ISO	●	●	1.5		6.35	3.04	0.8	1.0	0.14	0.87	
		MMT11IR175ISO	●	●	1.75		6.35	3.04	0.9	1.1	0.10	1.01	
		MMT11IR200ISO	●	●	2.0		6.35	3.04	0.9	1.1	0.18	1.15	
		MMT16IR050ISO	●	●	0.5		9.525	3.44	0.6	0.4	0.03	0.29	
		MMT16IR075ISO	●	●	0.75		9.525	3.44	0.6	0.6	0.04	0.43	
		MMT16IR100ISO	●	●	1.0		9.525	3.44	0.6	0.7	0.10	0.58	
		MMT16IR125ISO	●	●	1.25		9.525	3.44	0.8	0.9	0.12	0.72	
		MMT16IR150ISO	●	●	1.5		9.525	3.44	0.8	1.0	0.14	0.87	
		MMT16IR175ISO	●	●	1.75		9.525	3.44	0.9	1.2	0.10	1.01	
		MMT16IR200ISO	●	●	2.0		9.525	3.44	1.0	1.3	0.18	1.15	
		MMT16IR250ISO	●	●	2.5		9.525	3.44	1.1	1.5	0.15	1.44	
		MMT16IR300ISO	●	●	3.0		9.525	3.44	1.1	1.5	0.26	1.73	
		MMT22IR350ISO	●	●	3.5		12.7	4.64	1.6	2.3	0.22	2.02	
		MMT22IR400ISO	●	●	4.0		12.7	4.64	1.6	2.3	0.25	2.31	
		MMT22IR450ISO	●	●	4.5		12.7	4.64	1.6	2.4	0.28	2.60	
		MMT22IR500ISO	●	●	5.0		12.7	4.64	1.6	2.3	0.32	2.89	

G

THREADING

IDENTIFICATION

MMT **16** **E** **R** **050** **ISO**

Designation

Hand of Tool

R Right

Pitch

050	0.5mm	A	0.5—1.5mm or 48—16 thread/inch
075	0.75mm		
100	1.0mm		
125	1.25mm		
150	1.5mm	G	1.75—3.0mm or 14—8 thread/inch
175	1.75mm		
200	2.0mm		
250	2.5mm	AG	0.5—3.0mm or 48—8 thread/inch
300	3.0mm		
350	3.5mm		
400	4.0mm	N	3.5—5.0mm or 7—5 thread/inch
450	4.5mm		
500	5.0mm		

Threading Type

60	Partial Profile 60°
55	Partial Profile 55°
ISO	ISO Metric
W	Whitworth for BSW, BSP
BSPT	BSPT
UN	American UN
RD	Round DIN 405
TR	ISO Trapezoidal 30°
ACME	American ACME
UNJ	UNJ
APBU	API Buttress Casing
APRD	API Round Casing&Tubing
NPT	NPT
NPTF	NPTF

Diameter of Inscribed Circle (mm)

11	6.35
16	9.525
22	12.7

Application

E	External
I	Internal

● : Inventory maintained in Japan. (5 inserts in one case)

Type	Thread Tolerance	Order Number	Coated		Pitch		Dimensions (mm)					Total Cutting Depth (mm)	Geometry
			VP10MF	VP15TF	mm	thread/inch	IC	S	PDY	PDX	RE		
American UN	2B	MMT11R320UN	●			32	6.35	3.04	0.6	0.6	0.04	0.46	
		MMT11R280UN	●			28	6.35	3.04	0.6	0.7	0.05	0.52	
		MMT11R240UN	●			24	6.35	3.04	0.7	0.8	0.09	0.61	
		MMT11R200UN	●			20	6.35	3.04	0.8	0.9	0.11	0.73	
		MMT11R180UN	●			18	6.35	3.04	0.8	1.0	0.12	0.81	
		MMT11R160UN	●			16	6.35	3.04	0.9	1.1	0.14	0.92	
		MMT11R140UN	●			14	6.35	3.04	0.9	1.1	0.11	1.05	
		MMT16R320UN	●			32	9.525	3.44	0.6	0.6	0.04	0.46	
		MMT16R280UN	●			28	9.525	3.44	0.6	0.7	0.05	0.52	
		MMT16R240UN	●			24	9.525	3.44	0.7	0.8	0.09	0.61	
		MMT16R200UN	●			20	9.525	3.44	0.8	0.9	0.11	0.73	
		MMT16R180UN	●			18	9.525	3.44	0.8	1.0	0.12	0.81	
		MMT16R160UN	●	●		16	9.525	3.44	0.9	1.1	0.14	0.92	
		MMT16R140UN	●	●		14	9.525	3.44	0.9	1.2	0.11	1.05	
		MMT16R130UN	●	●		13	9.525	3.44	1.0	1.3	0.10	1.13	
		MMT16R120UN	●	●		12	9.525	3.44	1.1	1.4	0.18	1.22	
		MMT16R110UN	●	●		11	9.525	3.44	1.1	1.5	0.13	1.33	
		MMT16R100UN	●	●		10	9.525	3.44	1.1	1.5	0.15	1.47	
		MMT16R090UN	●	●		9	9.525	3.44	1.2	1.7	0.17	1.63	
		MMT16R080UN	●	●		8	9.525	3.44	1.1	1.5	0.27	1.83	
MMT22R070UN	●	●		7	12.7	4.64	1.6	2.3	0.23	2.09			
MMT22R060UN	●	●		6	12.7	4.64	1.6	2.3	0.26	2.44			
MMT22R050UN	●	●		5	12.7	4.64	1.6	2.3	0.32	2.93			
Whitworth for BSW, BSP	Medium Class A	MMT11R190W	●			19	6.35	3.04	0.8	1.0	0.19	0.86	
		MMT11R140W	●			14	6.35	3.04	0.9	1.1	0.26	1.16	
		MMT16R280W	●			28	9.525	3.44	0.6	0.7	0.09	0.58	
		MMT16R260W	●			26	9.525	3.44	0.7	0.8	0.10	0.63	
		MMT16R200W	●			20	9.525	3.44	0.8	0.9	0.18	0.81	
		MMT16R190W	●	●		19	9.525	3.44	0.8	1.0	0.19	0.86	
		MMT16R180W	●	●		18	9.525	3.44	0.8	1.0	0.20	0.90	
		MMT16R160W	●	●		16	9.525	3.44	0.9	1.1	0.23	1.02	
		MMT16R140W	●	●		14	9.525	3.44	1.0	1.2	0.26	1.16	
		MMT16R120W	●	●		12	9.525	3.44	1.1	1.4	0.30	1.36	
		MMT16R110W	●	●		11	9.525	3.44	1.1	1.5	0.33	1.48	
		MMT16R100W	●	●		10	9.525	3.44	1.1	1.5	0.37	1.63	
		MMT16R090W	●	●		9	9.525	3.44	1.2	1.7	0.34	1.81	
		MMT16R080W	●	●		8	9.525	3.44	1.2	1.5	0.39	2.03	
		MMT22R070W	●	●		7	12.7	4.64	1.6	2.3	0.46	2.32	
		MMT22R060W	●	●		6	12.7	4.64	1.6	2.3	0.53	2.71	
MMT22R050W	●	●		5	12.7	4.64	1.7	2.4	0.66	3.25			
BSPT	Standard BSPT	MMT11R190BSPT	●			19	6.35	3.04	0.8	0.9	0.14	0.86	
		MMT11R140BSPT	●			14	6.35	3.04	0.9	1.0	0.26	1.16	
		MMT16R190BSPT	●	●		19	9.525	3.44	0.8	0.9	0.14	0.86	
		MMT16R140BSPT	●	●		14	9.525	3.44	1.0	1.2	0.26	1.16	
		MMT16R110BSPT	●	●		11	9.525	3.44	1.1	1.5	0.33	1.48	
Round DIN 405	7H	MMT16R100RD	●			10	9.525	3.44	1.1	1.2	0.55	1.27	
		MMT16R080RD	●			8	9.525	3.44	1.4	1.4	0.70	1.59	
		MMT16R060RD	●			6	9.525	3.44	1.4	1.5	0.93	2.12	
		MMT22R040RD	●			4	12.7	4.64	2.2	2.3	1.40	3.18	



THREADING

MMT G-CLASS GROUND INSERTS

INSERTS

Type	Thread Tolerance	Order Number	Coated VP10MF	Pitch		Dimensions (mm)					Total Cutting Depth (mm)	Geometry
				mm	thread/inch	IC	S	PDY	PDX	RE RER/L		
ISO Trapezoidal 30°	7H	MMT16R150TR	●	1.5		9.525	3.44	1.0	1.1	0.08	0.90	Semi-full form
		MMT16R200TR	●	2.0		9.525	3.44	1.1	1.3	0.15	1.25	
		MMT16R300TR	●	3.0		9.525	3.44	1.3	1.5	0.15	1.75	
		MMT22R400TR	●	4.0		12.7	4.64	1.7	1.9	0.15	2.25	
		MMT22R500TR	●	5.0		12.7	4.64	2.1	2.5	0.15	2.75	
American ACME	3G	MMT16R120ACME	●		12	9.525	3.44	1.2	1.3	0.05	1.19	Semi-full form
		MMT16R100ACME	●		10	9.525	3.44	1.2	1.3	0.08	1.52	
		MMT16R080ACME	●		8	9.525	3.44	1.4	1.5	0.10	1.84	
		MMT22R060ACME	●		6	12.7	4.64	1.8	2.1	0.10	2.37	
		MMT22R050ACME	●		5	12.7	4.64	2.0	2.3	0.10	2.79	
UNJ												When machining an internal UNJ thread, cut an internal hole with the appropriate diameter. Then machine with 60° American UN. In this case, a full form type insert cannot be used.
API Buttress Casing	Standard API	MMT22R050APBU	●		5	12.7	4.64	2.8	1.9	0.74/0.18	1.55	Full form
API Round Casing & Tubing	Standard API RD	MMT16R100APRD	●		10	9.525	3.44	1.2	1.4	0.34	1.41	Full form
		MMT16R080APRD	●		8	9.525	3.44	1.3	1.5	0.41	1.81	
American NPT	Standard NPT	MMT16R270NPT	●		27	9.525	3.44	0.7	0.8	0.04	0.66	Full form
		MMT16R180NPT	●		18	9.525	3.44	0.8	1.0	0.08	1.01	
		MMT16R140NPT	●		14	9.525	3.44	0.9	1.2	0.09	1.33	
		MMT16R115NPT	●		11.5	9.525	3.44	1.1	1.5	0.11	1.64	
		MMT16R080NPT	●		8	9.525	3.44	1.3	1.8	0.14	2.42	
American NPTF	Class 2	MMT16R140NPTF	●		14	9.525	3.44	0.9	1.2	0.04	1.35	Full form
		MMT16R115NPTF	●		11.5	9.525	3.44	1.1	1.5	0.04	1.63	
		MMT16R080NPTF	●		8	9.525	3.44	1.3	1.8	0.04	2.38	

● : Inventory maintained in Japan. (5 inserts in one case)

MICRO-MINI TWIN

CT STANDARD

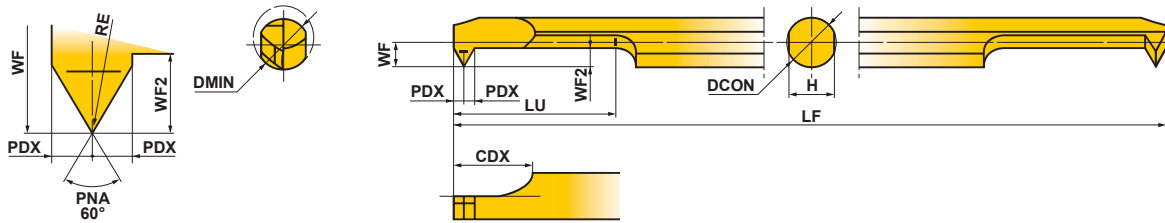

Order Number	Stock		Breaker	Threads				Dimensions (mm)									
	Micro Grain Carbide	Coated		Metric Screw		Unified Coarse Screw		DMIN	RE	DCON	LF	LU	CDX	WF	PDX	WF2	H
				Thread	Pitch (mm)	Thread	Pitch (thread/inch)										
	TF15	VP15TF															
CT0305RS-M4	●	●	Without	≥ M4	0.5—1.0	≥ NO.8-32UNC	36—24	3	0.03	3	50	5.2	6	1.3	0.6	1.2	2.7
CT03RS-M4	●	●	Without	≥ M4	0.5—1.0	≥ NO.8-36UNF	36—24	3	0.03	3	50	10.2	6	1.3	0.6	1.2	2.7
CT03RS-M4B	●	●	With	≥ M4	0.5—1.0		36—24	3	0.03	3	50	10.2	6	1.3	0.6	1.2	2.7
CT0407RS-M6	●	●	Without	≥ M6	0.75—1.25	≥ 1/4-20UNC	28—20	4.5	0.05	4	60	7.6	7	1.8	0.8	1.7	3.6
CT04RS-M6	●	●	Without	≥ M6	0.75—1.25	≥ 1/4-28UNF	28—20	4.5	0.05	4	60	15.6	7	1.8	0.8	1.7	3.6
CT04RS-M6B	●	●	With	≥ M6	0.75—1.25		28—20	4.5	0.05	4	60	15.6	7	1.8	0.8	1.7	3.6
CT0511RS-M8	●	●	Without	≥ M8	0.75—1.5	≥ 5/16-18UNC	24—18	6	0.05	5	70	11	8	2.3	1	2.2	4.5
CT05RS-M8	●	●	Without	≥ M8	0.75—1.5	≥ 5/16-24UNF	24—18	6	0.05	5	70	21	8	2.3	1	2.2	4.5
CT05RS-M8B	●	●	With	≥ M8	0.75—1.5		24—18	6	0.05	5	70	21	8	2.3	1	2.2	4.5
CT0611RS-M10	●	●	Without	≥ M10	0.75—1.75	≥ 3/8-16UNC	24—16	7	0.05	6	75	11	8	2.8	1	2.2	5.4
CT06RS-M10	●	●	Without	≥ M10	0.75—1.75	≥ 3/8-24UNF	24—16	7	0.05	6	75	21	8	2.8	1	2.2	5.4
CT06RS-M10B	●	●	With	≥ M10	0.75—1.75		24—16	7	0.05	6	75	21	8	2.8	1	2.2	5.4

G
THREADING

RECOMMENDED CUTTING CONDITIONS

Work Material	Cutting Speed (m/min)	Recommended Tool Overhang (mm)
P Carbon Steel Alloy Steel	50 (30—80)	
M Stainless Steel	50 (30—80)	
K Cast Iron	50 (30—80)	
N Non-Ferrous Metal	80 (50—100)	

Note 1) Wet cutting is recommended.
Note 2) Pay special attention to machining of small diameters at high revolutions as the feed rate cannot keep up with the speed.

STANDARD OF DEPTH OF CUT

● The chart on the right shows the cutting depths when machining external ISO metric screw threads.

● Metric

		(mm)					
P(Pitch)		0.50	0.75	1.00	1.25	1.50	1.75
Total Cutting Depth		0.29	0.43	0.58	0.72	0.87	1.01
Number of Passes	1	0.06	0.06	0.07	0.07	0.07	0.07
	2	0.05	0.06	0.06	0.07	0.07	0.07
	3	0.05	0.05	0.06	0.07	0.07	0.07
	4	0.04	0.05	0.05	0.07	0.07	0.07
	5	0.03	0.04	0.05	0.06	0.06	0.07
	6	0.03	0.04	0.05	0.06	0.06	0.06
	7	0.02	0.04	0.04	0.05	0.06	0.06
	8	0.01	0.03	0.04	0.05	0.06	0.06
	9	—	0.03	0.04	0.05	0.05	0.06
	10	—	0.02	0.03	0.04	0.05	0.05
	11	—	0.01	0.03	0.04	0.05	0.05
	12	—	—	0.03	0.03	0.04	0.05
	13	—	—	0.02	0.03	0.04	0.04
	14	—	—	0.01	0.02	0.03	0.04
	15	—	—	—	0.01	0.03	0.04
	16	—	—	—	—	0.03	0.03
	17	—	—	—	—	0.02	0.03
	18	—	—	—	—	0.01	0.03
	19	—	—	—	—	—	0.03
	20	—	—	—	—	—	0.02
	21	—	—	—	—	—	0.01

● : Inventory maintained in Japan. (MICRO-MINI TWIN is available in 1 piece in one pack.)

SPARE PARTS > Q001
TECHNICAL DATA > R001

G033

■ PRECAUTIONS WHEN USING THE MICRO-MINI TWIN

● When using a holder for general purpose / small automatic lathe:

① To avoid chipping of the 2nd cutting edge take care when inserting the boring bar into the holder. Refer to fig.1. If the 2nd edge contacts the internal face of the holder there is a possibility that it may chip.

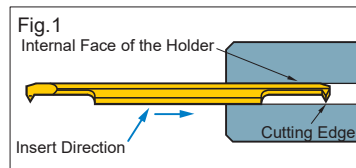

② When using this type of holder, there is a possibility that damage to the shank and the 2nd cutting edge can occur. Make sure that the clamping screws are tightened to the set torque value. Additionally make sure that there is no clamping screw near the 2nd cutting edge as this can break the boring bar.

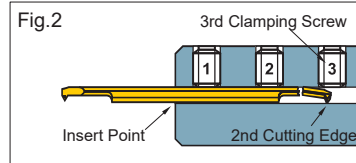

◎ When using Mitsubishi holders

When using holders with a tool overhang of recommended quantity, ensure that the 3rd clamping screw is removed prior to machining. The set torque value for clamping screw is 2.0 N·m.

● When using a square type holder:

① When installing the boring bar into the holder, tighten the clamp screws after ensuring the flats on the tool holder are parallel to the reference flats on the micro-mini bar. Refer to fig.3.

② Make sure that the clamping screws are tightened to the recommended values.

③ Do not tighten the clamp screw without a bar in place, otherwise the bridge will be deformed.

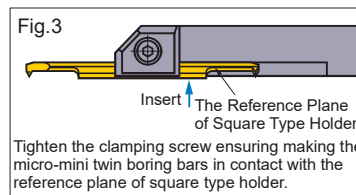

G

THREADING

SQUARE TYPE HOLDER

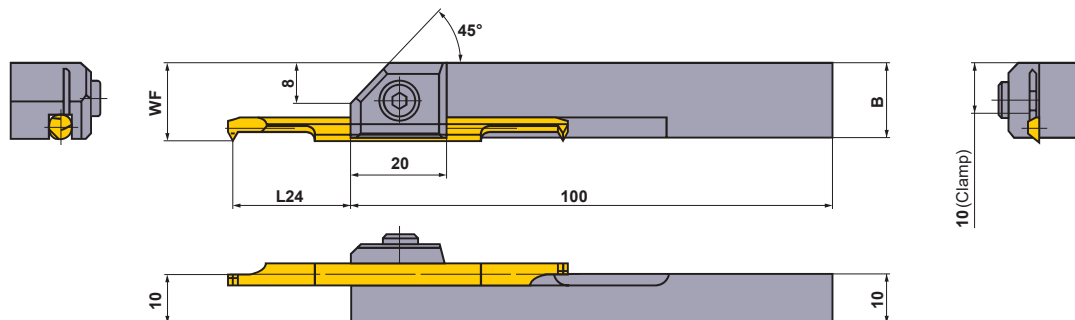

Order Number	Stock	Dimensions (mm)			Micro-Mini Twin CT	Clamp Screw	Wrench	Torque (N·m)
		Micro-Mini Twin CT						
		B	WF	* L24				
SBH1030R	●	13.8	13.8	13—17.5(14)	0305RS-M4, 03RS-M4(B)	HSC05012	HKY40R	9.5
SBH1040R	●	14.7	14.8	18.5—22(19.5)	0407RS-M6, 04RS-M6(B)	HSC05012	HKY40R	9.5
SBH1050R	●	15.6	15.8	24—26.5(25)	0511RS-M8, 05RS-M8(B)	HSC05012	HKY40R	9.5
SBH1060R	●	16.5	16.8	24—31.5(25)	0611RS-M10, 06RS-M10(B)	HSC05012	HKY40R	9.5

* L24 is the length of overhang for sufficient clamping, and () is the recommended length for machining of carbon and alloy steel.

● : Inventory maintained in Japan.

ROUND TYPE HOLDER

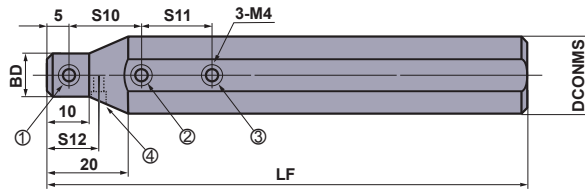
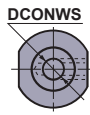

RBH2200N has a temporary set screw for different machine specifications.
(Represented by number 4)

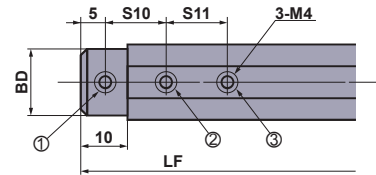

RBH1580N, RBH1600N,
RBH1900N

Order Number	Stock	Dimensions (mm)						Micro-Mini Twin CT	*1 Clamp Screw				Wrench	Torque (N•m)	
		DCONMS	DCONWS	BD	LF	S10	S11		S12	①	②	③			④
RBH15830N	●	15.875	3	15	100	10	10	—	0305RS-M4, 03RS-M4(B)	A	A	A	—	HKY20F	2.0
RBH15840N	●	15.875	4	15	100	15	15	—	0407RS-M6, 04RS-M6(B)	A	A	A	—	HKY20F	2.0
RBH15850N	●	15.875	5	15	100	15	15	—	0511RS-M8, 05RS-M8(B)	A	A	A	—	HKY20F	2.0
RBH15860N	●	15.875	6	15	100	15	15	—	0611RS-M10, 06RS-M10(B)	A	A	A	—	HKY20F	2.0
RBH1630N	●	16	3	15	100	10	10	—	0305RS-M4, 03RS-M4(B)	A	A	A	—	HKY20F	2.0
RBH1640N	●	16	4	15	100	15	15	—	0407RS-M6, 04RS-M6(B)	A	A	A	—	HKY20F	2.0
RBH1650N	●	16	5	15	100	15	15	—	0511RS-M8, 05RS-M8(B)	A	A	A	—	HKY20F	2.0
RBH1660N	●	16	6	15	100	15	15	—	0611RS-M10, 06RS-M10(B)	A	A	A	—	HKY20F	2.0
*2 RBH19030N	●	19.05	3	18	125	10	10	—	0305RS-M4, 03RS-M4(B)	B	B	B	—	HKY20F	2.0
*2 RBH19040N	●	19.05	4	18	125	15	15	—	0407RS-M6, 04RS-M6(B)	B	B	B	—	HKY20F	2.0
*2 RBH19050N	●	19.05	5	18	125	15	15	—	0511RS-M8, 05RS-M8(B)	B	B	B	—	HKY20F	2.0
*2 RBH19060N	●	19.05	6	18	125	15	15	—	0611RS-M10, 06RS-M10(B)	B	B	B	—	HKY20F	2.0
RBH2030N	●	20	3	12	125	10	10	—	0305RS-M4, 03RS-M4(B)	A	A	B	—	HKY20F	2.0
RBH2040N	●	20	4	13	125	15	15	—	0407RS-M6, 04RS-M6(B)	A	B	B	—	HKY20F	2.0
RBH2050N	●	20	5	14	125	15	15	—	0511RS-M8, 05RS-M8(B)	A	B	B	—	HKY20F	2.0
RBH2060N	●	20	6	15	125	15	15	—	0611RS-M10, 06RS-M10(B)	A	B	B	—	HKY20F	2.0
RBH2230N	●	22	3	12	125	10	10	10	0305RS-M4, 03RS-M4(B)	A	B	C	A	HKY20F	2.0
RBH2240N	●	22	4	13	125	15	15	12.5	0407RS-M6, 04RS-M6(B)	A	B	B	A	HKY20F	2.0
RBH2250N	●	22	5	14	125	15	15	12.5	0511RS-M8, 05RS-M8(B)	A	B	B	A	HKY20F	2.0
RBH2260N	●	22	6	15	125	15	15	15	0611RS-M10, 06RS-M10(B)	A	B	B	A	HKY20F	2.0
RBH2530N	●	25	3	12	150	10	10	—	0305RS-M4, 03RS-M4(B)	A	B	C	—	HKY20F	2.0
RBH2540N	●	25	4	13	150	15	15	—	0407RS-M6, 04RS-M6(B)	A	C	C	—	HKY20F	2.0
RBH2550N	●	25	5	14	150	15	15	—	0511RS-M8, 05RS-M8(B)	A	C	C	—	HKY20F	2.0
RBH2560N	●	25	6	15	150	15	15	—	0611RS-M10, 06RS-M10(B)	A	C	C	—	HKY20F	2.0
RBH25430N	●	25.4	3	12	150	10	10	—	0305RS-M4, 03RS-M4(B)	A	B	C	—	HKY20F	2.0
RBH25440N	●	25.4	4	13	150	15	15	—	0407RS-M6, 04RS-M6(B)	A	C	C	—	HKY20F	2.0
RBH25450N	●	25.4	5	14	150	15	15	—	0511RS-M8, 05RS-M8(B)	A	C	C	—	HKY20F	2.0
RBH25460N	●	25.4	6	15	150	15	15	—	0611RS-M10, 06RS-M10(B)	A	C	C	—	HKY20F	2.0

*1 Order number of clamp screw A=HSS04004, B=HSS04006, C=HSS04008

*2 Revised order number.

Conventional Order Number	Revised Order Number
RBH1930N	RBH19030N
RBH1940N	RBH19040N
RBH1950N	RBH19050N
RBH1960N	RBH19060N



THREADING

THREADING

F TYPE BORING BARS

- Minimum cutting diameter 10mm.
- Screw-on type.
- Applicable to threading, grooving.
- Thread pitch 1.5–3.5mm.

FSL51

Internal threading, Grooving

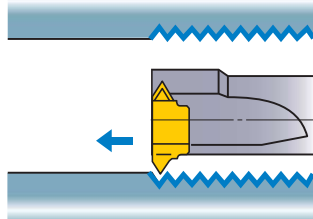

Note 1) Cutting in the opposite direction is not possible.

1 Corner Type
(FSL5108R, 5110R)

2 Corner Type
(FSL5112R, 5114R, 5116R)

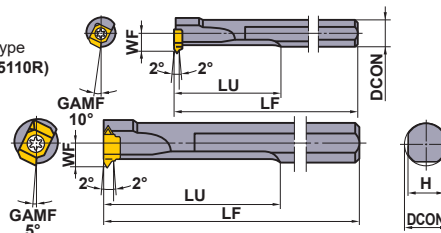

Right hand tool holder only.

Order Number	Stock R	Insert Number		Dimensions (mm)						*2	
		Threading	Grooving	DCON	LF	LU	WF	H	DMIN*1	Clamp Screw	Wrench
FSL5108R	●	MLT1001L	MLG10 \odot L	8	125	30	4.8	7	10	TS25	TKY08F
FSL5110R	●	MLT1001L	MLG10 \odot L	10	150	40	5.8	9	12	TS25	TKY08F
FSL5112R	●	MLT1401L	MLG14 \odot L	12	180	50	6.8	10.8	14	TS32	TKY08F
FSL5114R	●	MLT1401L	MLG14 \odot L	14	180	60	7.8	12.4	16	TS32	TKY08F
FSL5116R	●	MLT2001L	MLG20 \odot L	16	200	70	9.7	14	20	TS43	TKY15F

*1 DMIN : Min.Cutting Diameter

*2 Clamp Torque (N · m) : TS25=1.0, TS32=1.0, TS43=3.5

G

THREADING

FSL52

(Carbide shank) Internal threading, Grooving

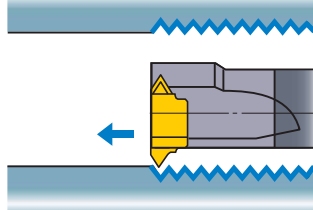

Note 1) Cutting in the opposite direction is not possible.

1 Corner Type
(FSL5208R, 5210R)

2 Corner Type
(FSL5212R, 5214R, 5216R)

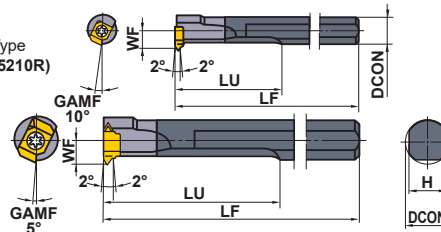

Right hand tool holder only.

Order Number	Stock R	Insert Number		Dimensions (mm)						*2	
		Threading	Grooving	DCON	LF	LU	WF	H	DMIN*1	Clamp Screw	Wrench
FSL5208R	●	MLT1001L	MLG10 \odot L	8	125	60	4.8	7	10	TS25	TKY08F
FSL5210R	●	MLT1001L	MLG10 \odot L	10	150	70	5.8	9	12	TS25	TKY08F
FSL5212R	●	MLT1401L	MLG14 \odot L	12	180	80	6.8	11	14	TS32	TKY08F
FSL5214R	●	MLT1401L	MLG14 \odot L	14	180	85	7.8	12	16	TS32	TKY08F
FSL5216R	●	MLT2001L	MLG20 \odot L	16	200	115	9.7	14	20	TS43	TKY15F

*1 DMIN : Min.Cutting Diameter

*2 Clamp Torque (N · m) : TS25=1.0, TS32=1.0, TS43=3.5

RECOMMENDED CUTTING CONDITIONS

Work Material	Hardness	Grade	Cutting Speed (m/min)	Work Material	Hardness	Grade	Cutting Speed (m/min)
P Mild Steel	≤180HB	UP20M	140 (100–180)	M Stainless Steel	≤200HB	UP20M	120 (80–150)
		UTi20T	120 (100–150)			UTi20T	100 (70–130)
Carbon Steel Alloy Steel	180–280HB	UP20M	120 (100–150)	K Gray Cast Iron	Tensile Strength ≤350MPa	UP20M	80 (60–100)
		UTi20T	100 (70–120)			UTi20T	80 (60–100)

● : Inventory maintained in Japan. (10 inserts in one case)

INSERTS

Type	Order Number	Coated	Carbide	Pitch and CW (mm)	Dimensions (mm)						Geometry
		UP20M	UTi20T		L	W1	CDX	S	BCH	RE	
Threading	MLT1001L	●	●	Pitch 1.5—2.0	7	5	—	2.38	—	0.1	
	MLT1401L	●	●	Pitch 1.5—2.5	11.8	6.5	—	4.76	—	0.1	
	MLT2001L	●	●	Pitch 1.5—3.5	16.8	9.03	—	6.35	—	0.1	
Grooving	MLG1012L		●	1.2	7	5	1.0	2.38	0.1	—	
	MLG1015L		●	1.5	7	5	1.0	2.38	0.1	—	
	MLG1020L		●	2	7	5	1.0	2.38	0.1	—	
	MLG1415L		●	1.5	11.8	6.5	2.0	4.76	0.1	—	
	MLG1420L		●	2	11.8	6.5	2.0	4.76	0.1	—	
	MLG1430L		●	3	11.8	6.5	2.0	4.76	0.1	—	
	MLG2020L		●	2	16.8	9.03	3.0	6.35	0.1	—	
	MLG2030L		●	3	16.8	9.03	3.0	6.35	0.1	—	
	MLG2040L		●	4	16.8	9.03	3.0	6.35	0.1	—	

Note 1) Please refer to the page F125 for cutting conditions of grooving.

STANDARD OF DEPTH OF CUT

- The chart on the right shows the cutting depths when machining external ISO metric screw threads.
- When you use cermet grades or cut stainless steel, please increase the number of passes by 2—3 times.

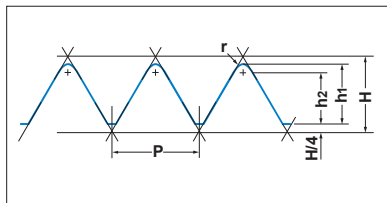

METRIC SCREW THREAD

P (Pitch)	0.75	1.00	1.25	1.50	1.75	2.00	2.50	3.00	3.50	
h1	0.43	0.58	0.72	0.87	1.01	1.15	1.44	1.73	2.02	
h2	0.38	0.51	0.63	0.76	0.88	1.01	1.21	1.51	1.77	
r (Corner Radius)	0.05	0.07	0.09	0.11	0.13	0.14	0.18	0.22	0.25	
Number of Passes	1	0.10	0.15	0.18	0.20	0.23	0.25	0.25	0.25	0.30
	2	0.10	0.13	0.15	0.20	0.20	0.20	0.22	0.25	0.25
	3	0.10	0.10	0.12	0.15	0.20	0.15	0.20	0.22	0.22
	4	0.08	0.10	0.12	0.15	0.15	0.15	0.20	0.20	0.20
	5	0.05	0.05	0.10	0.10	0.10	0.15	0.15	0.20	0.20
	6		0.05	0.05	0.07	0.08	0.10	0.10	0.15	0.20
	7					0.05	0.10	0.10	0.12	0.15
	8						0.05	0.10	0.10	0.15
	9							0.07	0.10	0.10
	10							0.05	0.09	0.10
	11								0.05	0.10
	12									0.05

Note 1) The first pass causes a high load on the cutting edge. In order to avoid damage, keep the depth of cut to 0.4—0.5mm maximum.

G

THREADING

THREADING

D TYPE BORING HEAD

- Minimum cutting diameter 40mm.
- Pin lock type.
- Exchangeable head type.
- Thread pitch $\leq 4.5\text{mm}$.

DPT2

Internal threading

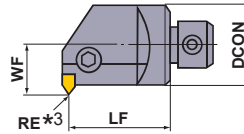
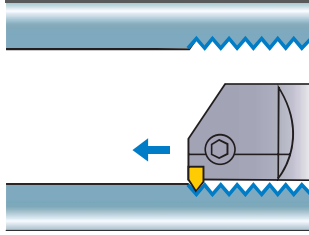

Right hand tool holder only.

Order Number	Stock R	Insert Number	Dimensions (mm)					Lock Pin	Lock Screw *1	Stop Ring	Wrench
			DCON	LF	WF	DMIN*2	RE*3				
DPT2132R	●	MTTL4360	32	40	20	40	0.1	P21S	HSP08014	E01	HKY40R
DPT2140R	●		40	50	25	50	0.1	P21S	HSP08014	E01	HKY40R

*1 Clamp Torque (N · m) : HSP08014=7.0

*2 DMIN : Min.Cutting Diameter

*3 Dimensions shown for insert corner RE 0.1.

G

THREADING

STANDARD OF DEPTH OF CUT

- The chart on the right shows the cutting depths when machining external ISO metric screw threads.
- When you use cermet grades or cut stainless steel, please increase the number of passes by 2–3 times.

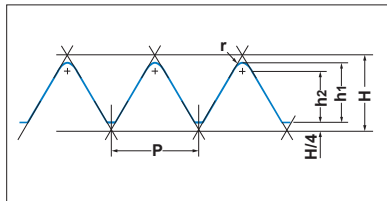

METRIC SCREW THREAD

P (Pitch)	0.75	1.00	1.25	1.50	1.75	2.00	2.50	3.00	3.50	4.00	4.50	
h1	0.43	0.58	0.72	0.87	1.01	1.15	1.44	1.73	2.02	2.31	2.60	
h2	0.38	0.51	0.63	0.76	0.88	1.01	1.21	1.51	1.77	2.02	2.28	
r (Corner Radius)	0.05	0.07	0.09	0.11	0.13	0.14	0.18	0.22	0.25	0.29	0.32	
Number of Passes	1	0.10	0.15	0.18	0.20	0.23	0.25	0.25	0.25	0.30	0.30	0.35
	2	0.10	0.13	0.15	0.20	0.20	0.20	0.22	0.25	0.25	0.25	0.30
	3	0.10	0.10	0.12	0.15	0.20	0.15	0.20	0.22	0.22	0.25	0.25
	4	0.08	0.10	0.12	0.15	0.15	0.15	0.20	0.20	0.20	0.25	0.25
	5	0.05	0.05	0.10	0.10	0.10	0.15	0.15	0.20	0.20	0.23	0.25
	6		0.05	0.05	0.07	0.08	0.10	0.10	0.15	0.20	0.20	0.20
	7					0.05	0.10	0.10	0.12	0.15	0.20	0.20
	8						0.05	0.10	0.10	0.15	0.15	0.15
	9							0.07	0.10	0.10	0.15	0.15
	10							0.05	0.09	0.10	0.10	0.15
	11								0.05	0.10	0.10	0.10
	12									0.05	0.08	0.10
	13										0.05	0.10
	14											0.05

Note 1) The first pass causes a high load on the cutting edge. In order to avoid damage, keep the depth of cut to 0.4–0.5mm maximum.

RECOMMENDED CUTTING CONDITIONS

Work Material	Hardness	Grade	Cutting Speed (m/min)
P Mild Steel	$\leq 180\text{HB}$	UP20M	140 (100–180)
		NX2525	200 (150–250)
		UTi20T	120 (100–150)
Carbon Steel Alloy Steel	180–280HB	UP20M	120 (100–150)
		NX2525	170 (150–200)
		UTi20T	100 (70–120)

Work Material	Hardness	Grade	Cutting Speed (m/min)
M Stainless Steel	$\leq 200\text{HB}$	UP20M	120 (80–150)
		UTi20T	100 (70–130)
K Gray Cast Iron	Tensile Strength $\leq 350\text{MPa}$	UP20M	80 (60–100)
		UTi20T	80 (60–100)
		HTi10	100 (70–130)

● : Inventory maintained in Japan. (10 inserts in one case)

INSERTS

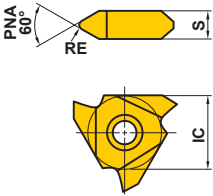
Type	Order Number	Class	Coated		Cermet	Carbide		ISO Pitch mm	Dimensions (mm)			Geometry
			UP20M	NX2525		UTi20T	HTi10		IC	S	RE	
Partial Profile 60°	MTTL436001	G	●			●	●	1.0—1.75	12.7	4.76	0.1	MTTL(60°) 
	MTTL436002	G		●		●		2.0—2.5	12.7	4.76	0.2	
	MTTL436003	G		●		●		3.0—3.5	12.7	4.76	0.3	

STANDARD ARBOR FOR D TYPE BORING HEAD

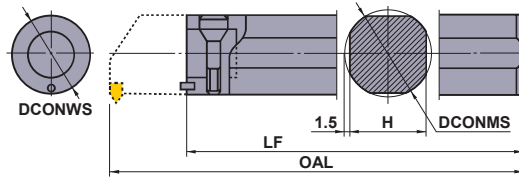

Order Number	Stock	Dimensions (mm)					Set Bolt	Wrench	Head
		DCONWS	DCONMS	LF	H	OAL			
B13232	●	32	32	260	29	300	SD32	HKY60R	DPT2132R
B14040	●	40	40	310	37	360	SD40	HKY60R	DPT2140R

G

THREADING

RANGE OF MACHINING

