

FIRST-CLASS COORDINATE MEASURING MACHINES

WENZEL LH SERIES

Precision that pays off



THE FAST AND EASY WAY
TO EXACT MEASUREMENT RESULTS

WENZEL LH SERIES

THE FAST AND EASY WAY TO EXACT MEASUREMENT RESULTS

With the LH you benefit from an extremely functional, effective and flexible measuring machine that is reliable and easy to operate. The success of our coordinate measuring machines is based on a proven holistic concept consisting of first-class mechanical engineering, intelligent software and accessory options and a comprehensive service package. Stable, reliable and fully dynamic, the LH is a universal and flexible measuring

instrument for a wide range of applications. With the current generation of air-bearing bridge machines, WENZEL continues the progress in precision, efficiency and longevity. With its revolutionary design, the LH impresses with high mechanical accuracy, perfect ergonomics and increased dynamics. CMMs of the LH series are available in the accuracy classes Standard, Premium and Premium-Select.

FEATURES

- **High-quality machine components** harmonize in perfect interaction and ensure long machine running times
- **Excellent long-term stability** due to air bearing guides incorporated into the granite base plate and high-precision lapped guide surfaces
- **Identical thermal behaviour** of granite in all axes
- **High-resolution scales** ensure exact positioning and precise measurement results
- **Innovative sensor technology** ensures precise detection of free-form surfaces and geometric elements
- **Perfect working ergonomics** for comfortable and safe operation
- **Highest investment security:** Modular design ensures future upgrade of the CMM

FIELDS OF APPLICATION

The LH is ideal for all applications requiring high accuracy and high throughput. The LH series is used in almost all areas of industry and measures components in detail from watch manufacture through to the production of large engines. The Y-axis can be customized in length for special sizes.

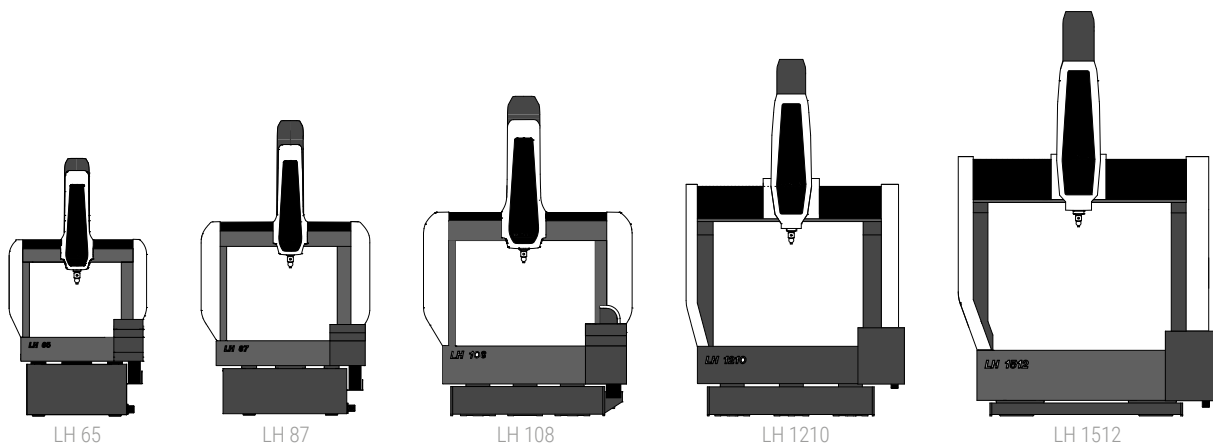



MEASURING ACCURACY

Type	Measuring ranges X x Y x Z (mm)	Volumetric length measuring uncertainty $E_{L, MPE}$ (μm) Premium Select
LH 65	650 x 750/1200 x 500	1,1 + L / 400
LH 87	800 x 1000/1500/2000 x 700	1,2 + L / 400
LH 108	1000 x 1200/1600/2000/3000 x 800	1,3 + L / 400
LH 1210	1200 x 1600/2000/2500/3000 x 1000	2,1 + L / 450
LH 1512	1500 x 2000/2500/3000 x 1200	2,3 + L / 450

Value $E_{L, MPE}$ only valid for SP80/SP25M/REVO touch probes.

Other Y-lengths on request. Subject to changes in design and scope of delivery as well as further technical development.

YOUR ADVANTAGES AT A GLANCE

■ Highest mechanical precision

Granite in all axes | Handcrafted |
Unique mechanical precision

■ Low operating costs

Low air consumption | Fast availability of reliable spare
parts

■ High flexibility

Customer-specific measuring volume |
Data compatibility | Suitable for automation

■ Versatile sensor options

Changeable sensor options | 3 or 5-axis scanning |
Optical sensors

■ Ergonomic design

Easy to operate | Ease of maintenance |
Aesthetic design

INNOVATION MEETS TRADITION

The WENZEL Group is a market leader in innovative Metrology. WENZEL offers a comprehensive product portfolio in the fields of Coordinate Metrology, Computed Tomography and Optical High Speed Scanning. The technology of WENZEL is used in all industries, including the automotive sector, aeronautics, power generation and

medicine. WENZEL looks at today on an installed base of more than 10,000 machines worldwide. Subsidiaries and agencies in more than 50 countries support sales and provide after-sales service for our customers. The WENZEL Group today employs more than 600 people.



YOUR LOCAL CONTACT PERSON

WENZEL GROUP GMBH & CO. KG

Werner-Wenzel-Straße

97859 Wiesthal

Phone: +49 6020 201-6006

E-Mail: sales@wenzel-group.com

We are there for you worldwide. You can find our subsidiaries, sales and service partners at **www.wenzel-group.com**.

